

technometall

EDELSTAHL

MEMBER OF **MDM** GROUP

INDUSTRIE UND GEWERBE



*Entscheidung
für
Beständigkeit*



www.technometall.at





Sehr geehrte Kunden & Partner

Seit 1980 bewährt sich technometall EDELSTAHL als beständiger Lieferant einer breiten Palette von EDELSTAHL Produkten. Auf einer Lagerfläche von mehr als 4.000 m² bewirtschaften wir viele gängige EDELSTAHL Artikel. Namhafte EDELSTAHL-Hersteller und -Werke zählen zu unseren langjährigen Lieferanten.

Unser **Basisprogramm für Industrie und Gewerbe** setzt sich aus EDELSTAHL Rohren und Rohrzubehör zusammen. Ebenso führen wir EDELSTAHL Gewindefittinge, Armaturen, Stabstahl und EDELSTAHL Bleche. Die Dimensionen erstrecken sich von Nennweite 6 bis 600 mm. EDELSTAHL Standardwerkstoffe sind 1.4301, 1.4306, 1.4307, 1.4541 aus der V2A-Gruppe, sowie 1.4432, 1.4404, 1.4571 aus der V4A-Gruppe.

Den Großteil dieses breiten EDELSTAHL Sortimentes haben wir ab Lager verfügbar – Sonderdimensionen und Sonderwerkstoffe (z.B. 1.4462, 1.4539, 1.4828, 1.4841, 1.4878, ...) können wir auf Anfrage kurzfristig und verlässlich liefern. Ebenso übernehmen wir die Herstellung von EDELSTAHL Sonderfertigungen nach Kundenvorgabe.

Bei allen Aufträgen sind wir stets bestrebt, dass unsere Geschäftspartner von unserem EDELSTAHL Know How, von hoher Liefertreue und von einer einfacheren, schnelleren und flexibleren Abwicklung deutlich profitieren! Aus diesen Qualitätskriterien und aus den hervorragenden technologischen Eigenschaften unseres Werkstoffes leitet sich unser Motto „Entscheidung für Beständigkeit“ ab – beständige Produkte von einem beständigen Unternehmen!

In der vorliegenden Produktübersicht geben wir einen Überblick zu unserem meist ab Lager verfügbaren Programm für Industrie und Gewerbe. Für Anfragen und Bestellungen wenden Sie sich bitte per Telefon, Fax oder E-Mail an unsere Kundenberaterinnen und Kundenberater, die Ihnen auch bei eventuellen technischen Fragen bzw. bei Sonderdimensionen und -werkstoffen jederzeit gerne weiterhelfen.

DI Dr. Ralph Klenner
Geschäftsführer

EDELSTAHL

für Industrie & Gewerbe

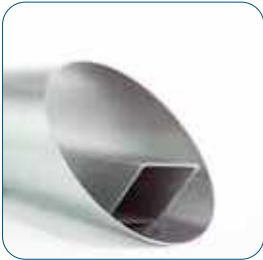

Rohre

5-14



Bögen

15-18



Reduzierungen

19-22



T-Stücke

23-26



Rohrkappen

27-28

Flansche
&
Bördel

29-36



Rohrschellen

37-38

Gewinde-Fittings
&
Armaturen

39-46



Stabstahl

47-50

Ringraumdichtungen
Schweißdraht
Niro-Zubehör

51-52

Getränke-
leitungsteile

53-54

Schneidring-
verschraubungen

55-56

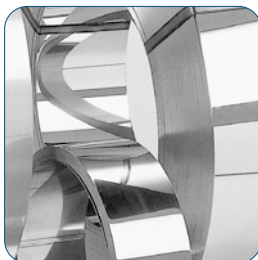
Bandstähle
&
Bleche

57-59

Weitere
Informationen &
Folder download
unter

www.technometall.at

Ansprechpartner

für Verkauf & Kundenberatung



Prof. Josef Mayr

Leitung Verkauf &
Kundenberatung
Tel 07242/44663-22
j.mayr@technometall.at



Karin Pohn

Verkauf &
Kundenberatung
Tel 07242/44663-20
k.pohn@technometall.at



Gabriele Bauer

Verkauf &
Kundenberatung
Tel 07242/44663-36
g.bauer@technometall.at



Alexandra Jentner

Verkauf &
Kundenberatung
Tel 07242/44663-21
a.jentner@technometall.at



Daniela Untersmayr

Verkauf &
Kundenberatung
Tel 07242/44663-23
d.untersmayr@technometall.at



Nina Lehner

Sekretariat &
Zeugnisverwaltung
Tel 07242/44663-37
n.lehner@technometall.at



Susanne Riedlhuber

Einkauf &
Materialwirtschaft
Tel 07242/44663-10
s.riedlhuber@technometall.at

Werkstoffvergleich und Zusammensetzung austenitischer CrNi-Stähle

Gruppe	Wkst.-Nr.	Bezeichnung			Chemische Zusammensetzung (Massenanteil in %)				
		EN 10088-3	AISI	SIS	C max.	Cr	Ni	Mo	Sonstiges
V2A	1.4301	X 5 CrNi 18 10	304	2332	0,07	17,0 - 19,5	8,0 - 10,5	-	-
	1.4307	X 2 CrNi 18 9	304 L	2352	0,03	17,5 - 19,5	8,0 - 10,0	-	-
	1.4541	X 6 CrNiTi 18 10	321	2337	0,08	17,0 - 19,0	9,0 - 12,0	-	Ti min. 5xC - max. 0,7
	1.4306	X 2 CrNi 19 11	304 L	2352	0,03	18,0 - 20,0	10,0 - 12,0	-	-
	1.4305	X 8 CrNiS 18 9	303	2346	0,10	17,0 - 19,0	8,0 - 10,0	-	S 0,15 - 0,35
V4A	1.4401	X 5 CrNiMo 17 12 2	316	2347	0,07	16,5 - 18,5	10,0 - 13,0	2,0 - 2,5	-
	1.4571	X 6 CrNiMoTi 17 12 2	316 TI	2350	0,08	16,5 - 18,5	10,5 - 13,5	2,0 - 2,5	Ti min. 5xC - max. 0,7
	1.4404	X 2 CrNiMo 17 12 2	316 L	2348	0,03	16,5 - 18,5	10,0 - 13,0	2,0 - 2,5	-
	1.4436	X 3 CrNiMo 17 13 3	316	2343	0,05	16,5 - 18,5	10,5 - 13,0	2,0 - 3,0	-
	1.4432	X 2 CrNiMo 17 12 3	316 L	2353	0,03	16,5 - 18,5	10,5 - 13,0	2,0 - 3,0	-
	1.4435	X 2 CrNiMo 18 14 3	316 L	2353	0,03	17,0 - 19,0	12,5 - 15,0	2,5 - 3,0	-
V5A	1.4539	X 1 NiCrMoCu 25-20-5	904 L	2562	0,02	19,0 - 21,0	24,0 - 26,0	4,0 - 5,0	Cu, N
V6A	1.4547	X 1 CrNiMoCuN 20-18-7	S31254	2378	0,02	19,5 - 20,5	17,5 - 18,5	6,0 - 7,0	Cu, N
	1.4529	X 1 NiCrMoCuN 25-20-7	-	-	0,02	19,0 - 21,0	24,0 - 26,0	6,0 - 7,0	Cu, N
Duplex	1.4462	X 2 CrNiMoN 22 5 3	S31803	2377	0,03	21,0 - 23,0	4,5 - 6,5	2,5 - 3,5	N

Rohre

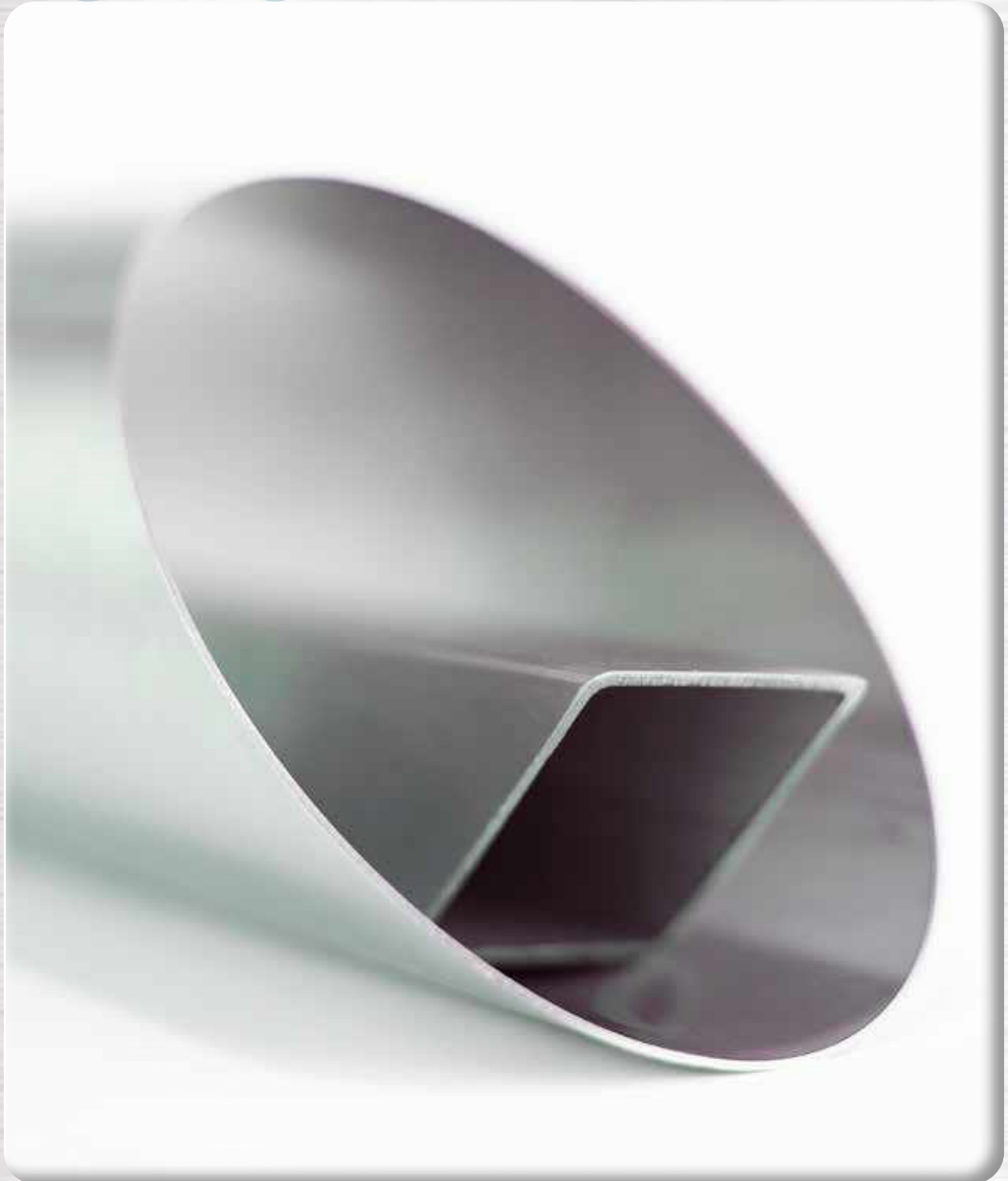

EDELSTAHL - Rohre

geschweißt - METRISCH



in HL zu 6m

ungeglüht, EN 10217-7 - w1/w2, Tol.: EN ISO 1127 - D3/T3 teilweise D2/T3.

Bestellbeispiel: Rohr EN 10217-7 - 104 x 2 - 1.4301 - w1

NW/ DN	AD x Wand mm	Gewicht kg/m	1.4301 / 1.4307 / AISI 304	1.4432 / 1.4404 / 1.4571 / AISI 316 L
4	6 x 1,0	0,13	○	●
6	8 x 1,0	0,18	○	●
8	10 x 1,0	0,23	○	●
	x 1,5	0,35	○	●
10	12 x 1,0	0,28	○	●
	x 1,5	0,42	○	●
	15 x 1,5	0,51	●	●
15	18 x 1,5	0,62	●	●
	20 x 1,5	0,70	●	●
	x 2,0	0,90	●	●
20	23 x 1,5	0,81	●	●
	25 x 1,5	0,88	●	●
	x 2,0	1,15	●	●
25	28 x 1,5	1,00	●	●
	30 x 1,5	1,07	○	○
	x 2,0	1,36	●	●
32	35 x 1,5	1,26	○	●
	x 2,0	1,68	●	●
	38 x 1,5	1,37	●	○
	x 2,0	1,81	○	●
	40 x 1,5	1,43	○	○
	x 2,0	1,91	●	●
40	43 x 1,5	1,56	●	●
	44,5 x 2,0	2,12	●	●
50	50 x 2,0	2,40	●	○
	53 x 1,5	1,95	●	●
	54 x 2,0	2,61	●	●
65	70 x 1,5	2,51	○	○
	x 2,0	3,36	●	●
80	83 x 1,5	3,07	○	●
	84 x 2,0	4,13	●	●
100	103 x 1,5	3,83	○	○
	104 x 2,0	5,12	●	●
	106 x 3,0	7,78	●	○
	108 x 2,0	5,31	●	○
	x 3,0	7,89	○	○
	x 4,0	10,50	●	○
125	128 x 1,5	4,76	○	○
	129 x 2,0	6,40	●	●
	131 x 3,0	9,65	○	○
	133 x 3,0	9,65	○	○
	x 4,0	13,00	●	○
150	153 x 1,5	5,72	○	○
	154 x 2,0	7,65	●	●
	156 x 3,0	11,60	●	●
	159 x 4,0	15,50	●	○
200	204 x 2,0	10,20	●	●
	205 x 2,5	12,80	○	○
	206 x 3,0	15,60	●	●
250	254 x 2,0	12,70	●	●
	255 x 2,5	15,90	○	○
	256 x 3,0	19,10	●	●
300	304 x 2,0	15,20	●	●
	305 x 2,5	19,00	○	○
	306 x 3,0	22,90	●	●

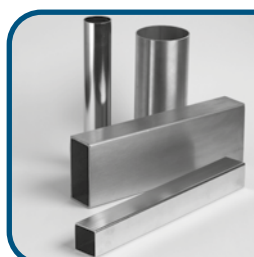

Größere Dimensionen siehe ISO-Abmessungen.

EDELSTAHL - Rohre

geschweißt - ISO

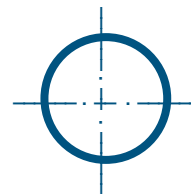

17
Entscheidung
für
Beständigkeit

in HL zu 6m

ungeglüht, EN 10217 - EN 10296-2 - w1/w2, Tol.: EN ISO 1127 - D3/T3 teilweise D2/T3.

Bestellbeispiel: Rohr EN 10217-7 - 168,3 x 2 - 1.4571 - w2

NW/ DN	ISO	AD x Wand mm	Gewicht kg/m	1.4301 / 1.4307 / AISI 304	1.4432 / 1.4404 / 1.4571 / AISI 316 L
8		13,5 x 1,6	0,48	○	○
	1/4"	nahtlos x 2,3	0,65	○	●
10		17,2 x 1,6	0,62	○	●
		x 2,0	0,76	●	○
	3/8"	x 2,3	0,87	○	●
15		21,3 x 1,6	0,79	○	○
		x 2,0	0,96	●	●
	1/2"	x 2,6	1,22	●	●
20		26,9 x 1,6	1,01	○	●
		x 2,0	1,24	●	●
	3/4"	x 2,6	1,60	●	●
25		33,7 x 1,6	1,20	○	○
		x 2,0	1,60	●	●
		x 2,6	2,03	●	○
	1"	x 3,2	2,45	●	●
32		42,4 x 1,6	1,64	○	○
		x 2,0	2,02	●	●
		x 2,6	2,59	○	○
	5/4"	x 3,2	3,14	●	●
40		48,3 x 1,6	1,87	○	●
		x 2,0	2,32	●	●
		x 2,6	2,98	○	○
	6/4"	x 3,2	3,62	●	●
50		60,3 x 1,2	1,78	●	○
		x 1,6	2,35	○	○
		x 2,0	2,92	●	●
		x 2,6	3,76	○	○
		x 3,0/3,2	4,31/4,58	●	●
	2"	x 3,6	5,10	●	●
65		76,1 x 1,6	2,99	○	○
		x 2,0	3,71	●	●
		x 2,6	4,79	○	○
		x 2,9/3,0	5,49	●	●
	2 1/2"	x 3,6	6,54	●	○
80		88,9 x 2,0	4,35	●	●
		x 2,6	5,62	○	○
		x 3,0/3,2	6,46/6,88	●	○
	3"	x 4,0	8,60	●	○
100		114,3 x 2,0	5,66	●	●
		x 2,6	7,27	○	○
		x 3,0	8,36	●	●
		x 3,6	9,98	○	●
		x 4,0	11,10	●	○
125		139,7 x 2,0	6,90	●	○
		x 2,6	8,93	○	○
		x 3,0	10,30	●	●
		x 4,0	13,59	●	○
150		168,3 x 2,0	8,33	●	●
		x 2,6	10,80	○	○
		x 3,0	12,40	●	●
		x 4,0	16,46	○	○
200		219,1 x 2,0	10,90	●	●
		x 2,6	13,70	○	○
		x 3,0	16,30	●	●
		x 4,0	21,60	○	○
		x 6,3	33,50	●	○
250		273,0 x 2,0	13,60	●	○
		x 2,6	17,00	○	○
		x 3,0	20,30	●	●
		x 4,0	27,00	●	●
300		323,9 x 2,0	16,10	○	○
		x 2,6	20,10	○	○
		x 3,0	24,10	●	●
350		355/355,6 x 2,6	22,10	○	○
		356/355,6 x 3,0	26,50	●	●
		x 4,0	35,30	○	●
400		406/406,4 x 3,0	30,30	●	●
		408/406,4 x 4,0	40,50	○	●
450		456/457,2 x 3,0	34,30	●	●
		458/457,2 x 4,0	45,80	○	○
500		506/508 x 3,0	37,90	●	●
		508 x 4,0	50,70	○	●
600		606/609,6 x 3,0	45,50	●	●
		608/609,6 x 4,0	60,60	○	●

EDELSTAHL - Rohre

geschweißt, EN ISO 1127 (DIN 2463) METRISCH

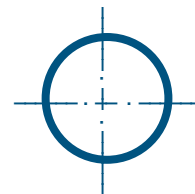

KONSTRUKTIONSRÖHRE ungeschliffen
DEKORATIONSRÖHRE geschliffen

ungeglüht, in HL zu 6m

Bestellbeispiel:

Rohr geschweißt EN ISO 1127 40 x 2 1.4301 geschliffen K220

AD x Wand mm	Gewicht kg/m	1.4301 / 1.4307 / AISI 304	
		ungeschliffen	geschliffen K 220
10 x 1,0	0,23	○	○
x 1,5	0,32	○	●
12 x 1,0	0,28	○	○
x 1,5	0,39	○	●
15 x 1,5	0,50	○	○
16 x 1,0	0,38	○	●
x 1,5	0,55	○	●
x 2,0	0,70	○	●
18 x 1,5	0,62	○	○
20 x 1,0	0,48	○	○
x 1,5	0,70	○	●
x 2,0	0,90	○	●
23 x 1,5	0,81	○	○
25 x 1,5	0,88	○	●
x 2,0	1,15	○	●
28 x 1,5	1,00	○	○
30 x 1,5	1,07	○	○
x 2,0	1,40	○	●
35 x 1,0	0,85	●	○
x 1,5	1,26	○	○
x 2,0	1,65	○	●
38 x 1,5	1,37	○	○
x 2,0	1,80	○	●
40 x 1,5	1,43	○	●
x 2,0	1,90	○	●
43 x 1,5	1,56	○	○
44,5/45 x 2,0	2,13/2,15	○	○
50 x 2,0	2,40	○	●
53 x 1,5	1,93	○	○
54 x 2,0	2,60	○	○
70 x 1,5	2,51	○	○
x 2,0	3,41	○	○
x 3,0	5,03	○	●
84 x 2,0	4,11	○	○
104 x 2,0	5,12	○	○
129 x 2,0	6,36	○	○
154 x 2,0	7,61	○	○



EDELSTAHL - Rohre

geschweißt, EN ISO 1127 (DIN 2463) ISO

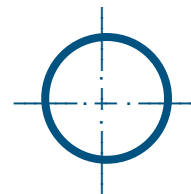

19
Entscheidung
für
Beständigkeit

KONSTRUKTIONSRÖHRE ungeschliffen
DEKORATIONSRÖHRE geschliffen
ungeglüht, in HL zu 6m

AD x Wand mm	Gewicht kg/m	1.4301 / 1.4307 / AISI 304	
		ungeschliffen	geschliffen K 220
17,2 x 2,0	0,76	○	○
21,3 x 1,5	0,74	○	○
x 2,0	0,97	○	●
26,9 x 2,0	1,25	○	●
x 2,5	1,52	○	○
33,7 x 1,5	1,21	○	○
x 2,0	1,59	○	●
x 2,5	1,95	○	○
x 3,0	2,29	○	○
42,4 x 1,5	1,53	○	○
x 2,0	2,02	○	●
x 2,5	2,49	○	○
48,3 x 2,0	2,32	○	●
x 2,5	2,87	○	○
x 3,0	3,39	○	○
60,3 x 1,5	2,21	○	○
x 2,0	2,92	○	●
x 2,5	3,62	○	○
x 3,0	4,29	○	○
76,1 x 2,0	3,71	○	○
x 3,0	5,48	○	○
88,9 x 2,0	4,35	○	○
x 2,5	5,40	○	○
x 3,0	6,56	○	○
114,3 x 2,0	5,62	○	○
x 3,0	8,36	○	○
139,7 x 2,0	6,90	○	○
x 3,0	10,27	○	○
168,3 x 2,0	8,33	○	○

EDELSTAHL - Rohre

nahtlos - METRISCH

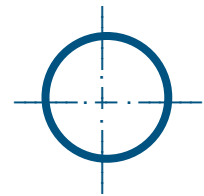

in HL zu 4-7 m
geglüht, gebeizt, EN 10216-5, Tol.: EN ISO 1127 - D4/T3
nahtloses Rohr EN 10216-5 - 10 x 1 - 1.4571

Bestellbeispiel:

AD x Wand mm	Gewicht kg/m	1.4301 / 1.4307 / AISI 304		1.4404 / 1.4571 / AISI 316 L	
6 x 1,0	0,125		○		●
6 x 1,5	0,160		○		●
8 x 1,0	0,175				●
x 1,5	0,244		○		●
10 x 1,0	0,225		○		●
x 1,5	0,319		○		●
x 2,0	0,410		○		●
12 x 1,0	0,275		○		●
x 1,5	0,394		○		●
x 2,0	0,501		○		●
14 x 1,0	0,326		○		○
x 1,5	0,471		○		○
x 2,0	0,601		○		●
15 x 1,0	0,351		○		○
x 1,5	0,507		○		●
x 2,0	0,651		○		●
16 x 1,0	0,376		○		●
x 1,5	0,545		○		○
x 2,0	0,701		○		●
18 x 1,0	0,426		○		○
x 1,5	0,621		○		●
x 2,0	0,801		○		●
20 x 1,0	0,476		○		○
x 1,5	0,695		○		○
x 2,0	0,901		○		●
22 x 1,5	0,771		○		●
x 2,0	1,002		○		●
x 2,5	1,221		○		●
25 X 1,5	0,883		○		○
X 2,0	1,152		○		○
x 2,5	1,409		○		○
x 3,0	1,605		○		○
28 x 1,5	0,995		○		○
x 2,0	1,302		○		●
x 2,5	1,600		○		●
x 3,0	1,878		○		○
30 x 1,5	1,071		○		○
x 2,0	1,402		○		○
x 3,0	2,028		○		○
35 x 1,5	1,258		○		○
x 2,0	1,653		○		○
x 3,0	2,404		○		○
38 x 1,5	1,371		○		○
x 2,0	1,803		○		○
x 3,0	2,629		○		○
42 x 2,0	2,003		○		○
x 3,0	2,931		○		○

EDELSTAHL - Rohre

nahtlos - ISO

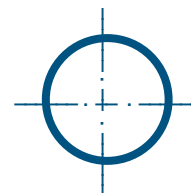

11
Entscheidung
für
Beständigkeit

in HL zu 4-7 m
geglüht, gebeizt, EN 10216-5, Tol.: EN ISO 1127 - D4/T3
nahtloses Rohr EN 10216-5 - 21,3 x 2,6 - 1.4571

Bestellbeispiel:

NW/ DN	AD x Wand mm	ISO	Gewicht kg/m	1.4301 / 1.4307 / AISI 304	1.4404 / 1.4571 / AISI 316 L
6	10,2 x 2,0	1/8"	0,411	○	○
8	13,5 x 1,6		0,477	○	○
	x 2,3	1/4"	0,645	○	●
10	17,2 x 1,6		0,625	○	○
	x 2,3	3/8"	0,858	○	○
15	21,3 x 2,0		0,967	○	○
	x 2,6	1/2"	1,217	○	○
20	26,9 x 2,0		1,247	○	○
	x 2,6	3/4"	1,582	○	○
25	33,7 x 2,0		1,588	○	○
	x 2,6		2,025	○	○
	x 3,25	1"	2,444	○	○
32	42,4 x 2,0		2,023	○	○
	x 2,6		2,591	○	○
	x 3,2	5/4"	3,141	○	○
40	48,3 x 2,0		2,319	○	○
	x 2,6		2,975	○	○
	x 3,2	6/4"	3,614	○	○
50	60,3 x 2,0		2,921	○	○
	x 2,6		3,757	○	○
	x 3,6	2"	5,111	○	○
65	76,1 x 2,9		5,315	○	○
	x 3,6	2 1/2"	6,535	○	○
80	88,9 x 3,05		6,557	○	○
	x 4,05	3"	8,605	○	○
100	114,3 x 2,6		7,272	○	○
	x 3,6		9,979	○	○
	x 4,5	4"	14,725	○	○
125	139,7 x 4,0		13,592	○	○
150	168,3 x 4,5		18,457	○	○
200	219,1 x 6,3		33,571	○	○
	x 8,18		43,211	○	○
	x 12,7		66,021	○	○

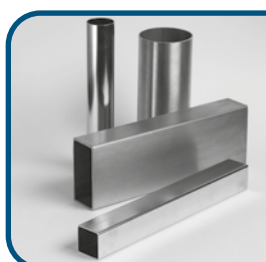

Andere Dimensionen und Werkstoffe
(z.B. 1.4462, 1.4539, 1.4828, 1.4841, 1.4878, ...) auf Anfrage.

EDELSTAHL - Formrohre

QUADRATISCH ähnlich DIN 2395

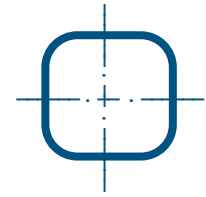

in HL zu 6m

Bestellbeispiel: Formrohr 40/40 x 2 1.4301 geschliffen K220

Querschnitt x Wand mm	Gewicht kg/m	1.4301 / 1.4307 / AISI 304		1.4404 / 1.4571	
		ungeschliffen	geschl. KORN 220	ungeschliffen	geschl. KORN 220
10 x 10 x 1,0	0,30	○	○	X	X
15 x 15 x 1,2	0,55	○	○	X	X
x 1,5	0,66	●	●	○	○
20 x 20 x 1,2	0,74	○	○	X	X
x 1,5	0,88	●	●	○	○
x 2,0	1,15	●	●	○	○
25 x 25 x 1,2	0,95	○	●	X	X
x 1,5	1,15	●	●	○	○
x 2,0	1,50	●	●	●	○
30 x 30 x 1,0	0,93	○	○	X	X
x 1,2	1,13	○	○	X	X
x 1,5	1,37	●	●	○	○
x 2,0	1,80	●	●	●	○
x 3,0	2,75	●	○	○	○
35 x 35 x 1,2	1,30	○	○	X	X
x 1,5	1,62	●	●	○	○
x 2,0	2,13	●	●	●	○
40 x 40 x 1,2	1,46	○	○	X	X
x 1,5	1,85	●	●	○	○
x 2,0	2,45	●	●	●	○
x 3,0	3,75	●	○	○	○
45 x 45 x 2,0	2,83	●	○	○	○
x 3,0	4,17	○	○	○	○
50 x 50 x 1,5	2,30	○	○	○	○
x 2,0	3,05	●	●	●	○
x 3,0	4,60	●	○	●	○
60 x 60 x 2,0	3,70	●	●	●	○
x 3,0	5,45	●	○	●	○
x 4,0	7,41	●	○	○	○
80 x 80 x 2,0	4,95	●	●	●	○
x 3,0	7,40	●	●	●	○
x 4,0	9,80	●	○	○	○
100 x 100 x 2,0	6,30	●	●	○	●
x 3,0	9,40	●	●	●	○
x 4,0	12,35	●	○	○	○
x 5,0	15,35	●	○	○	○
120 x 120 x 3,0	11,80	●	●	○	○
x 4,0	15,22	○	○	○	○
x 5,0	18,65	○	○	○	○
150 x 150 x 3,0	13,80	○	○	○	○
x 4,0	18,15	○	○	○	○
x 5,0	22,40	○	○	○	○
200 x 200 x 4,0	24,50	○	○	○	○
x 5,0	30,40	○	○	○	○
250 x 250 x 5,0	38,40	○	○	○	○

EDELSTAHL - Formrohre

RECHTECKIG ähnlich DIN 2395

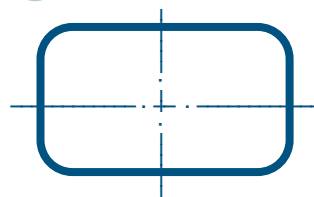

in HL zu 6m



Bestellbeispiel: Formrohr 30/20 x 1,5 1.4301

Querschnitt x Wand mm	Gewicht kg/m	1.4301 / 1.4307 / AISI 304		1.4404 / 1.4571	
		ungeschliffen	geschl. KORN 220	ungeschliffen	geschl. KORN 220
20 x 10 x 1,2	0,54	○	○	X	X
x 1,5	0,66	●	○	○	○
25 x 10 x 1,5	0,80	○	○	○	○
30 x 10 x 1,5	0,88	○	○	○	○
30 x 15 x 1,5	1,00	○	○	○	○
x 2,0	1,37	○	●	○	○
30 x 20 x 1,5	1,15	○	○	○	○
x 2,0	1,50	●	●	○	○
40 x 20 x 1,2	1,10	○	○	X	X
x 1,5	1,35	●	○	○	○
x 2,0	1,80	●	●	●	○
40 x 30 x 2,0	2,12	●	○	○	○
x 3,0	3,19	●	○	○	○
50 x 25 x 1,5	1,75	○	○	○	○
x 2,0	2,30	●	○	○	○
50 x 30 x 1,5	1,85	○	○	○	○
x 2,0	2,45	●	●	○	○
50 x 30 x 3,0	3,70	○	○	○	○
60 x 30 x 1,5	2,10	○	○	○	○
x 2,0	2,75	●	●	○	○
60 x 40 x 1,5	2,30	○	○	○	○
x 2,0	3,05	●	●	●	●
x 3,0	4,60	●	○	○	○
80 x 40 x 2,0	3,70	●	●	●	○
x 3,0	5,45	●	○	○	○
80 x 60 x 2,0	4,35	○	○	○	○
x 3,0	6,61	●	○	○	○
100 x 40 x 2,0	4,35	○	○	○	○
x 3,0	6,45	○	○	○	○
100 x 50 x 2,0	4,78	○	○	○	○
x 3,0	6,85	●	●	●	○
100 x 60 x 2,0	4,95	○	○	○	○
x 3,0	7,40	●	○	○	○
120 x 40 x 2,0	5,10	○	○	●	○
120 x 60 x 2,0	5,60	○	○	○	○
x 3,0	8,35	●	●	○	○
x 4,0	11,05	○	○	○	○
120 x 80 x 3,0	9,35	○	●	○	○
x 4,0	12,40	●	○	○	○
150 x 50 x 3,0	9,35	○	○	○	○
x 4,0	12,40	○	○	○	○
150 x 100 x 3,0	11,40	○	○	○	○
x 4,0	14,97	○	○	○	○
x 5,0	18,40	○	○	○	○
200 x 100 x 3,0	13,80	○	○	○	○
x 4,0	18,17	○	○	○	○
x 5,0	22,40	○	○	○	○
250 x 150 x 5,0	30,04	○	○	○	○

Präzisions-Metalbandsäge

Technische Parameter

Mit unserer Präzisions-Bandsägemaschine können wir folgende Schnitte bzw. Gehrungsschnitte ausführen:

Schnittbereich	\varnothing		
90°	460 mm	550 x 450 mm	450 x 450 mm
60°	250 mm	250 x 400 mm	250 x 250 mm
45°	400 mm	400 x 400 mm	400 x 400 mm



Neu!
Präzisions-
Bandsäge-
maschine !

Bögen



EDELSTAHL - Bögen

90° EN 10253-3/4 Typ A/B METRISCH geschweißt

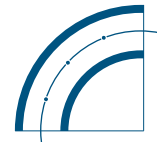

Bestellbeispiel: Bogen EN 10253-4 - 104 x 2 1.4301

NW/ DN	AD x Wand mm	1.4301 / 1.4307 / 1.4541 / AISI 304L / 321			1.4571 / 1.4404 / 1.4432 / AISI 316L		
		Bauart 3	Bauart 5	R=D+100	Bauart 3	Bauart 5	R=D+100
		3S / R=1,5*D	5S / R=2,5*D		3S / R=1,5*D	5S / R=2,5*D	
12	15 x 1,5	○	X	X	●	X	X
15	18 x 1,5	○	X	X	●	X	X
	20 x 1,5	○	X	X	●	X	X
	x 2,0	○	X	X	●	X	X
20	23 x 1,5	○	○	X	●	○	X
	25 x 2,0	○	X	X	●	X	X
25	28 x 1,5	○	○	X	●	○	X
	x 2,0	○	X	X	●	X	X
	30 x 2,0	○	○	X	●	○	X
32	35 x 1,5	○	X	X	●	X	X
	x 2,0	○	X	X	●	X	X
	38 x 1,5	○	X	X	●	X	X
	x 2,0	○	X	X	●	X	X
	40 x 1,5	●	X	X	X	X	X
	x 2,0	●	○	X	●	○	X
40	43 x 1,5	●	X	X	●	X	X
	44,5 x 2,0	●	○	X	●	●	X
50	50 x 2,0	●	X	X	○	X	X
	53 x 1,5	●	X	X	●	X	X
	54 x 2,0	●	○	X	●	○	X
65	70 x 2,0	●	○	X	●	○	X
80	84 x 2,0	●	○	X	●	○	●
100	104 x 2,0	●	○	○	●	○	○
	101,6 x 2,0	●	○	○	○	○	○
	106 x 3,0	X	X	○	●	X	○
125	129 x 2,0	●	○	○	●	○	○
	131 x 3,0	X	X	○	X	X	○
	133 x 3,0	○	X	○	○	X	○
150	154 x 2,0	●	○	●	●	○	●
	156 x 3,0	●	X	○	●	X	○
	159 x 3,0	●	X	○	○	X	○
200	204 x 2,0	●	○	●	●	○	●
	205 x 2,5	X	X	○	●	X	●
	206 x 3,0	●	X	●	●	X	●
250	254 x 2,0	○	X	●	○	X	●
	255 x 2,5	X	X	○	○	X	○
	256 x 3,0	○	X	●	○	X	●
300	304 x 2,0	○	X	●	○	X	●
	305 x 2,5	X	X	●	X	X	○
	306 x 3,0	○	X	●	○	X	●
350	356 x 3,0	○	X	●	○	X	●
	358 x 4,0	X	X	○	X	X	●
400	406 x 3,0	○	X	●	○	X	●
	408 x 4,0	X	X	○	X	X	○
450	456 x 3,0	X	X	●	X	X	○
	458 x 4,0	X	X	○	X	X	○
500	506 x 3,0	X	X	●	X	X	○
	508 x 4,0	X	X	○	X	X	●
600	606 x 3,0	X	X	○	X	X	○
	608 x 4,0	X	X	○	X	X	○

EDELSTAHL - Bögen

90° EN 10253-3/4 Typ A/B ISO
geschweißt

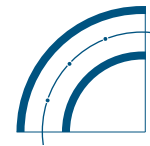

17
Entscheidung
für
Beständigkeit

Bestellbeispiel: Bogen EN 10253-4 - 168,3 x 2 1.4571

NW/ DN	ISO	AD x Wand mm	1.4301 / 1.4307 / 1.4541 / AISI 304L / 321		1.4571 / 1.4404/ 1.4432 / AISI 316L	
			Bauart 3	Bauart 5	Bauart 3	Bauart 5
			3S / R=1,5*D	5S / R=2,5*D	3S / R=1,5*D	5S / R=2,5*D
10	3/8"	17,2 x 1,6	○	X	○	X
		x 2,3	nahtlos X	X	●	X
15	1/2"	21,3 x 1,6	○	○	●	○
		x 2,0	○	○	●	○
20	3/4 "	x 2,6	○	X	●	○
		26,9 x 2,0	○	○	●	●
25	1"	x 2,6	○	X	●	X
		x 1,6	○	○	●	○
32	5/4"	33,7 x 2,0	○	○	●	●
		x 2,6	○	X	●	X
40	6/4"	x 3,2	○	X	●	X
		42,4 x 2,0	○	○	●	●
50	2"	x 2,6	○	X	●	○
		x 3,2	○	X	●	X
65	2 1/2"	48,3 x 1,6	○	X	●	X
		x 2,0	○	○	●	●
80	3"	x 2,6	○	X	●	X
		x 3,2	○	X	●	X
100		60,3 x 1,6	○	X	●	X
		x 2,0	●	○	●	●
125		x 2,6	●	X	●	○
		x 2,9/3,0	○	X	●	X
150		x 3,6	○	X	●	X
		76,1 x 2,0	●	○	●	○
200		x 2,6	●	X	●	○
		x 2,9/3,0	●	X	●	X
250		x 3,6	○	X	●	X
		88,9 x 2,0	●	○	●	●
300		x 2,6	●	X	●	○
		x 3,0	●	X	●	X
350		x 4,05	○	X	○	X
		114,3 x 2,0	●	○	●	○
400		x 2,6	●	○	●	○
		x 3,0	●	○	●	○
450		139,7 x 2,0	●	○	●	○
		x 4,0	●	X	○	X
500		x 2,6	○	○	●	○
		x 2,9/3,0	●	○	●	○
550		168,3 x 2,0	●	○	●	○
		x 2,5/2,6	○	○	●	○
600		x 3,0	●	○	●	○
		219,1 x 2,0	●	○	●	○
650		x 2,5/2,6	○	○	○	○
		x 3,0	●	○	●	○
700		273,1 x 2,5	○	○	○	○
		x 3,0	●	○	●	○
750		x 4,0	○	○	○	○
		323,9 x 2,5	○	○	○	○
800		x 3,0	●	○	●	○
		x 4,0	●	○	●	○
850		355,6 x 3,0	●	○	●	○
		x 4,0	○	○	○	○
900		406,4 x 3,0	●	○	●	○
		x 4,0	●	○	○	○
950		457,2 x 3,0	○	○	○	○
		x 4,0	○	○	○	○
1000		508,0 x 3,0	○	X	○	X
		x 4,0	○	X	○	X
1100		609,6 x 4,0	○	X	○	X

Grafische Darstellung der Bogen - Bauarten

Bauart 2	Bauart 3	Bauart 5
Mittlerer Biegeradius $r \sim 1 \times D$ ANSI: short radius	Standard Rohrbogen Mittlerer Biegeradius $r \sim 1,5 \times D$ Früher: 3S, 3d benannt ANSI: long radius	Mittlerer Biegeradius $r \sim 2,5 \times D$ Früher: 5S benannt

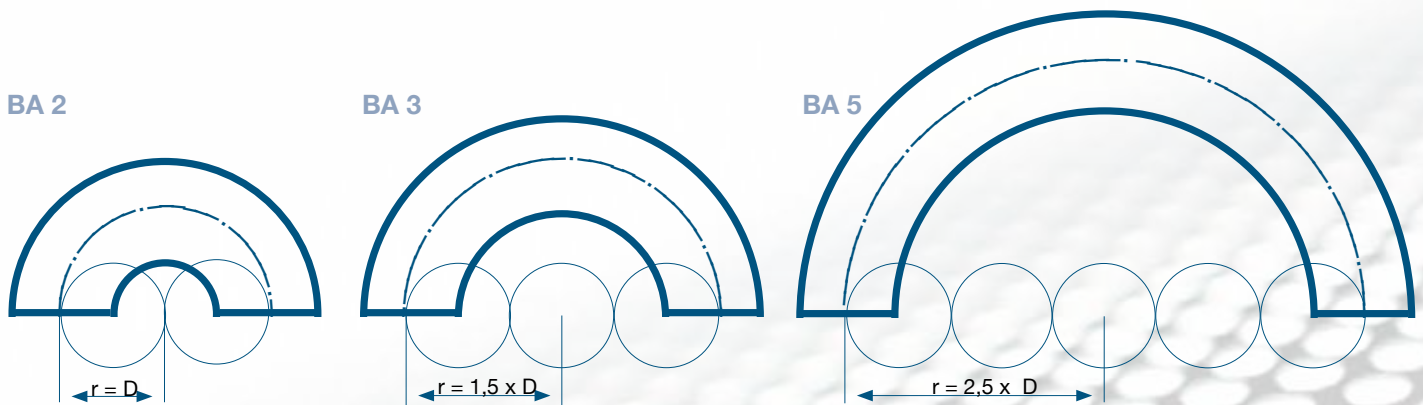

Weitere Bezeichnungen

- BA4 entspricht $r \sim 2 \times D$
- BA6 entspricht $r \sim 3 \times D$
- BA10 entspricht $r \sim 5 \times D$



**EDELSTAHL Know How
aus erster Hand**

Reduzierungen



EDELSTAHL - Reduzierung

EN 10253-3/4 Typ A/B ISO

gepresst, gebeizt, geschweißt

Bestellbeispiel: Reduzierstück EN10253-4 K 168,3 x 2,9 1.4571

NW/DN / NW/DN D / d		AD / AD mm		Stärke mm	Länge L mm	1.4541 / 1.4301 / 1.4307		1.4432 / 1.4571 / AISI 316 L / 1.4404	
						konzentrisch	exzentrisch	konzentrisch	exzentrisch
15	10	21,3	17,2	2,0	38	○	●	●	●
20	15	26,9	21,3	2,0	38	○	○	●	●
	10		17,2	2,0	38	●	●	●	●
25	20	33,7	26,9	2,0	50	●	●	●	●
	15		21,3	2,0	50	○	●	●	●
32	25	42,4	33,7	2,0	50	●	●	●	●
	20		26,9	2,0	50	○	●	●	●
	15		21,3	2,0	50	●	●	●	●
40	32	48,3	42,4	2,0	64	●	○	●	●
	25		33,7	2,0	64	●	●	●	●
	20		26,9	2,0	64	●	●	●	●
	15		21,3	2,0	64	●	●	●	●
50	40	60,3	48,3	2,0	76	○	●	●	○
	32		42,4	2,0	76	○	●	●	○
	25		33,7	2,0	76	●	○	●	○
	20		26,9	2,0	76	●	○	○	○
65	50	76,1	60,3	2,3	90	○	●	●	○
	40		48,3	2,3	90	○	●	●	●
	40		48,3	2,6	90	●	○	○	○
	32		42,4	2,3	90	○	●	○	●
	25		33,7	2,3	90	○	○	○	○
80	25	88,9	33,7	3,0	90	○	○	○	●
	65		76,1	2,3	90	○	○	●	○
	50		60,3	2,3	90	●	●	●	●
	40		48,3	2,3	90	●	●	●	○
	32		42,4	2,3	90	●	●	○	●
100	80	114,3	88,9	2,6	100	○	○	●	○
	65		76,1	2,6	100	○	○	●	●
	50		60,3	2,6	100	○	○	●	○
	40		48,3	2,6	100	○	○	●	○
125	100	139,7	114,3	2,6	127	○	○	●	○
	80		88,9	2,6	127	○	○	●	○
	65		76,1	2,6	127	○	○	●	○
	50		60,3	2,9	127	○	○	○	○
150	125	168,3	139,7	2,9	140	○	○	●	○
	100		114,3	2,9	140	○	○	●	○
	80		88,9	2,9	140	○	○	●	○
	65		76,1	2,9	140	○	○	○	○
200	150	219,1	168,3	3,0	152	○	○	●	○
	125		139,7	3,2	152	○	○	●	○
	100		114,3	3,2	152	○	○	●	○

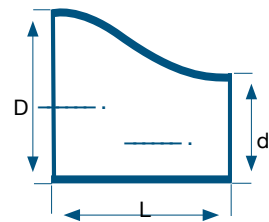
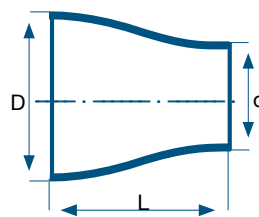

*Entscheidung
für
Beständigkeit*

EDELSTAHL - Reduzierungen

konzentrisch METRISCH TYP H

$$L = (D-d) \times 3 \quad \text{EN 10253-3/4 Typ A/B}$$

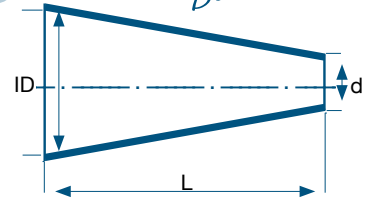

Bestellbeispiel: Reduzierung konzentrisch Typ H 154/104 x 2 1.4571

NW/DN / NW/DN D / d mm		Länge L	1.4301 / 1.4307				AISI 316L / 1.4404 / 1.4571			
			konzentrisch		exzentrisch		konzentrisch		exzentrisch	
			Stärke 2 mm	Stärke 3 mm	Stärke 2 mm	Stärke 3 mm	Stärke 2 mm	Stärke 3 mm	Stärke 2 mm	Stärke 3 mm
20	15	15	○	X	○	X	●	X	○	X
25	20	15	○	X	○	X	●	X	○	X
	15	30	○	X	○	X	●	X	○	X
32	25	21	○	X	○	X	●	X	●	X
	20	36	○	X	○	X	●	X	○	X
	15	51	○	X	○	X	●	X	●	X
40	32	24	○	X	○	X	●	X	●	X
	25	45	○	X	○	X	●	X	●	X
	20	60	○	X	○	X	●	X	●	X
50	40	30	○	X	○	X	●	X	●	X
	32	54	○	X	○	X	●	X	●	X
	20	90	○	X	○	X	●	X	○	X
	25	75	○	X	○	X	●	X	●	X
65	50	45	○	X	○	X	●	X	●	X
	40	75	○	X	○	X	●	X	●	X
	32	99	○	X	○	X	●	X	●	X
80	65	45	○	X	○	X	●	X	●	X
	50	90	○	X	○	X	●	X	●	X
	40	120	○	X	○	X	●	X	●	X
100	80	60	○	X	○	X	●	X	●	X
	65	105	○	X	○	X	●	X	●	X
	50	150	○	X	○	X	●	X	●	X
125	100	75	○	○	○	X	●	○	●	X
	80	135	○	○	○	X	●	○	●	X
	65	180	○	X	○	X	●	X	●	X
	50	225	○	X	○	X	●	X	○	X
150	125	75	○	○	○	X	●	●	●	X
	100	150	○	○	○	X	●	●	●	X
	80	210	○	○	○	X	●	○	●	X
200	150	150	○	○	○	○	●	●	●	●
	125	225	○	○	○	○	●	●	●	○
	100	300	○	○	○	○	○	●	●	○
	80	360	○	X	○	X	○	X	○	X
250	200	150	○	○	○	○	●	●	●	●
	150	300	○	○	○	○	●	●	○	●
	125	375	○	○	○	○	●	○	●	○
300	250	150	○	○	○	○	○	●	○	●
	200	300	○	○	○	○	○	●	○	●
	150	450	○	○	○	○	○	○	○	●
350	300	150	○	○	○	○	○	●	○	●
	250	300	○	○	○	○	○	●	○	●
	200	450	○	○	○	○	○	○	○	○
400	350	150	X	○	X	○	X	●	X	●
	300	300	X	○	X	○	X	●	X	●
	250	450	X	○	X	○	X	●	X	●
	200	600	X	○	X	○	X	○	X	○
450	400	150	X	○	X	○	X	●	X	○
	350	300	X	○	X	○	X	○	X	●
	300	450	X	○	X	○	X	○	X	●
500	450	150	X	●	X	○	X	●	X	●
	400	300	X	●	X	○	X	●	X	●
	350	450	X	○	X	○	X	○	X	●
	300	600	X	○	X	○	X	●	X	●
600	500	300	X	X	X	○	X	●	X	○
	400	600	X	○	X	○	X	○	X	○
	350	750	X	○	X	○	X	○	X	○

EDELSTAHL - Reduzierungen

ISO **TYP H** / $L = (D-d) \times 3$
 EN 10253-3/4 Typ A/B

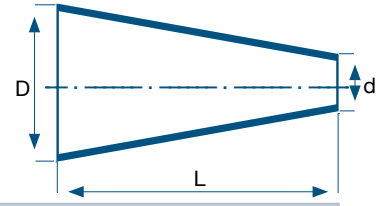

Bestellbeispiel: Reduzierung Typ H 168,3/114,3 x 2 1.4571

NW/DN / NW/DN D/d mm		AD / AD mm		Länge L mm	1.4301 / 1.4307				AISI 316L / 1.4404 / 1.4571			
					konzentrisch		exzentrisch		konzentrisch		exzentrisch	
					Stärke 2 mm	Stärke 3 mm	Stärke 2 mm	Stärke 3 mm	Stärke 2 mm	Stärke 3 mm	Stärke 2 mm	Stärke 3 mm
20	15	26,9	21,3	17	○	X	○	X	●	X	○	X
25	20	33,7	26,9	20	○	X	○	X	●	X	○	X
	15		21,3	37	○	X	○	X	●	X	○	X
	10		17,2	49	○	X	○	X	●	X	○	X
32	25	42,4	33,7	26	○	X	○	X	●	X	○	X
	20		26,9	46	○	X	○	X	●	X	○	X
	15		21,3	62	○	X	○	X	●	X	○	X
40	32	48,3	42,4	18	○	X	○	X	●	X	○	X
	25		33,7	43	○	X	○	X	●	X	○	X
	20		26,9	63	○	X	○	X	●	X	○	X
50	40	60,3	48,3	35	○	X	○	X	●	X	○	X
	32		42,4	53	○	X	○	X	●	X	○	X
	25		33,7	79	○	X	○	X	●	X	○	X
65	50	76,1	60,3	47	○	X	○	X	●	X	○	X
	40		48,3	82	○	X	○	X	●	X	○	X
	32		42,4	100	○	X	○	X	●	X	○	X
80	65	88,9	76,1	38	○	○	○	○	●	○	○	○
	50		60,3	85	○	○	○	○	●	○	○	○
	40		48,3	120	○	X	○	X	●	X	○	X
100	80	114,3	88,9	75	○	○	○	○	●	○	○	○
	65		76,1	113	○	○	○	○	●	○	○	○
	50		60,3	160	○	X	○	X	●	X	○	X
125	100	139,7	114,3	75	○	○	○	○	●	○	○	○
	80		88,9	150	○	○	○	○	●	○	○	○
	65		76,1	188	○	X	○	X	○	X	○	X
150	125	168,3	139,7	85	○	○	○	○	●	○	○	○
	100		114,3	160	○	○	○	○	●	○	○	○
	80		88,9	235	○	○	○	○	○	○	○	○
200	150	219,1	168,3	150	○	○	○	○	●	○	○	○
	125		139,7	235	○	○	○	○	●	○	○	○
	100		114,3	310	○	○	○	○	●	●	○	○
250	200	273,0	219,1	160	○	○	○	○	○	●	○	○
	150		168,3	310	○	○	○	○	○	●	○	○
	125		139,7	395	○	○	○	○	○	○	○	X
300	250	323,9	273,0	150	○	○	○	○	○	●	○	○
	200		219,1	310	○	○	○	○	○	○	○	○
	150		168,3	461	○	○	○	○	○	○	○	○
350	300	355,6	323,9	94	X	○	X	○	X	●	X	○
	250		273,0	254	X	○	X	○	X	○	X	○
	200		219,1	404	X	○	X	○	X	○	X	○
400	350	406,4	355,6	150	X	○	X	○	X	○	X	○
	300		323,9	244	X	○	X	○	X	○	X	○
	250		273,0	395	X	○	X	○	X	○	X	○
450	400	456,0	406,0		X	○	X	X	X	●	X	X

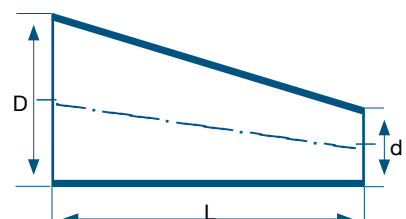
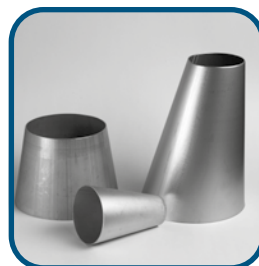

T-Stücke



EDELSTAHL - T-Stücke

EN 10253-3/4 Typ A/B METRISCH

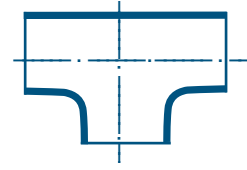

Bestellbeispiel: T-Stück gepresst ähnlich EN 10253-3 156 x 3 1.4571

NW/DN	AD x Wand mm	1.4541 / 1.4301 / 1.4307 / AISI 304		1.4432 / 1.4571 / 1.4404 / AISI 316L	
		bis NW 250 ausgehalst	gepresst ähnlich DIN 2615	bis NW 250 ausgehalst	gepresst ähnlich DIN 2615
		ab NW 300 eingeschweißt		ab NW 300 eingeschweißt	
15	20 x 2,0	X	X	X	●
20	25 x 2,0	X	X	X	●
	28 x 1,5	○	X	●	○
25	30 x 2,0	X	X	X	●
32	35 x 2,0	X	X	X	●
	38 x 2,0	X	X	X	○
40	44,5 x 2,0	X	X	●	●
50	54 x 2,0	○	X	●	●
65	70/69 x 2,0	○	X	●	●
80	84 x 2,0	○	X	●	●
100	104 x 2,0	○	X	●	●
125	129 x 2,0	○	X	●	●
150	154 x 2,0	○	X	●	X
	156 x 3,0	○	X	●	●
200	204 x 2,0	○	X	●	X
	206 x 3,0	○	X	●	●
250	254 x 2,0	○	X	○	X
	256 x 3,0	○	X	●	●
300	306 x 3,0	○	X	○	●

EDELSTAHL - T-Stücke

EN 10253-3/4 Typ A/B ISO (ausgenommen ANSI)

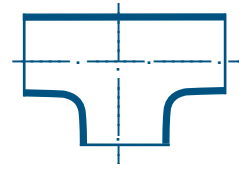

Bestellbeispiel: T-Stück gepresst EN 10253-3 114,3 x 3 1.4571

NW/DN	AD x Wand mm	1.4541 / 1.4301 / 1.4307 / AISI 304		1.4432 / 1.4571 / 1.4404 / AISI 316L	
		bis NW 250 ausgehalst	gepresst DIN 2615	bis NW 250 ausgehalst	gepresst DIN 2615
		ab NW 300 eingeschweißt		ab NW 300 eingeschweißt	
10	17,2 x 1,6	○	X	○	○
15	21,3 x 1,6	○	X	●	X
	x 2,0	○	○	○	●
	21,3 x	X	ANSI ○	X	ANSI ●
20	2,11	○	X	●	○
	26,9 x 1,6	○	○	○	●
	x 2,0	X	ANSI ○	X	ANSI ●
25	26,7 x	○	○	○	○
	2,11	○	○	●	●
	33,7 x 1,6	X	ANSI ○	X	ANSI ●
	33,7 x 2,0	X	ANSI ○	X	ANSI ●
32	33,4 x 2,77	○	○	●	●
	33,4 x 3,38	X	ANSI ○	X	ANSI ●
	42,4 x 2,0	X	ANSI ○	X	ANSI ○
40	42,2 x 2,77	○	○	●	●
	42,2 x 3,56	X	ANSI ○	X	ANSI ●
50	48,3 x 2,0	○	○	●	●
	48,3 x 2,77	X	ANSI ○	X	ANSI ●
	60,3 x 2,0	X	ANSI ○	X	ANSI ●
65	60,3 x 2,77	○	○	●	●
	60,3 x 3,91	X	○	X	●
80	76,1 x 2,0	○	○	●	●
	x 2,9/3,0	X	ANSI ○	X	ANSI ●
100	88,9 x 2,0	○	○	●	○
	88,9 x 3,05	X	ANSI ○	X	ANSI ●
125	114,3 x 2,0	○	X	●	X
	114,3 x	○	○	○	●
	3,05	X	ANSI ○	X	ANSI ●
150	139,7 x 2,0	○	X	●	X
	x 2,9/3,0	○	○	○	○
	141,3 x 3,4	X	ANSI ○	X	ANSI ●
200	168,3 x 2,0	○	X	●	X
	x 2,9/3,0	○	○	●	○
	168,3 x 3,40	X	ANSI ○	X	ANSI ●
250	219,1 x 2,0	○	○	●	○
	x 2,9/3,0	X	ANSI ○	X	ANSI ●
300	219,1 x 3,76	○	○	●	○
	273,0 x 2,9/3,0	○	○	○	○
350	273,1 x 4,19	○	X	○	X
400	323,9 x 3,0	○	X	○	X
500	x 4,0	○	X	○	X
600	355,6 x 4,0	○	X	○	

Präzise.
Flexibel.
Schnell.

EDELSTAHL

Sonderanfertigungen

1

Kosten-
Senkung
durch Fremd-
fertigung?



Industriesysteme



Laserzuschnitte



Leuchte pulverbeschichtet



Industriesysteme

2

Auf Basis
Ihrer Zeichnung
legen wir ein
Angebot.



Sonderflansche



Verteilungssysteme



Ascher



Abdeckbleche

3

Sie treffen die
Entscheidung
ob Eigen- oder
Fremdfertigung.



Flanschverbindungen



WT-Platten



Radparker glasperlgestraht



Rohrverbindungen

Folder download &
weitere Informationen unter
www.technometall.at

*Entscheidung
für
Beständigkeit*

Unsere Kundenberater informieren gerne im Detail

Rohrkappen



EDELSTAHL - Rohrkappen / Böden / Klöpferböden

ähnlich DIN 28011



Bestellbeispiel: Klöpferboden DIN 28011 219,1 x 3 1.4571

NW/ DN	METRISCH AD x Wand mm	1.4541 / 304L	1.4571 / 316L	ISO AD x Wand mm	1.4541 / 304L	1.4571 / 316L
10				17,2 x 2,0	○	○
15	20 x 2,0	○	○	21,3 x 2,0	○	●
	23 x 2,0	○	○			
20	25 x 2,0	○	○	26,9 x 2,5	○	●
	28 x 2,0	○	○			
25	30 x 2,0	○	○	33,7 x 3,0	○	●
	35 x 2,0	○	○			
	38 x 2,5	○	●			
40	40 x 2,5	○	●	48,3 x 3,0	○	●
	44,5 x 2,0	○	○			
50	50 x 2,0	○	○	60,3 x 3,0	○	●
	54 x 2,0	○	●			
	56 x 3,0	○	●			
65	70 x 3,0	○	●	76,1 x 3,0	○	●
	84 x 2,0	○	○			
80	86 x 3,0	○	●	88,9 x 3,0	○	●
	104 x 2,0	○	●			
100	106 x 3,0	○	●	114,3 x 3,0	○	●
	129 x 2,0	○	●			
125	131 x 3,0	○	○	139,7 x 3,0	○	●
	154 x 2,0	○	●			
150	156 x 3,0	○	●	168,3 x 3,0	○	●
	204 x 2,0	○	○			
200	206 x 3,0	○	●	219,1 x 3,0	○	●
	254 x 2,0	○	○			
250	256 x 3,0	○	●	273,0 x 3,0	○	●
	306 x 3,0		●			
300				323,9 x 3,0	○	●
350				355,6 x 3,0	○	●
400				406,4 x 3,0	○	●
450				457,0 x 4,0	○	○
500				508,0 x 3,0	○	○
				508,0 x 4,0	○	●
600				609,6 x 3,0	○	○
				609,6 x 4,0	○	○
700				711,0 x 4,0	○	○
800				813,0 x 4,0	○	○
900				914,0 x 4,0	○	○
				1016,0 x 4,0	○	○

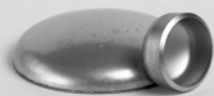

Andere Werkstoffe, Dimensionen,
sowie andere Bodenformen auf Anfrage.

Flansche & Bördel

29
*Entscheidung
für
Beständigkeit*



ALUMINIUM-Losflansche

PN 10

DN	D	b	k	z	d2	DIN 2642	DIN 2642	DIN 2673		DIN 16963	d4	Gewicht (kg)
						metrisch Typ A d6	ISO Typ C d6	ISO Typ D d5	metrisch Typ D d5	Typ E d6		
10	90	12	60	4	14	16	19	28	25		40	0,16
15	95	12	65	4	14	24	24	34	32	28	45	0,16
20	105	12	75	4	14	28	30	40	38	34	58	0,20
25	115	16	85	4	14	33	36	48	45	42	68	0,34
32	140	16	100	4	18	42	46	60	55	51	78	0,52
40	150	16	110	4	18	48	54	66	62	62	88	0,58
50	165	18	125	4	18	60	65	78	75	78	102	0,82
65	185	18	145	4	18	73	81	92		92	122	0,98
80	200	20	160	8	18	90	94	108		108	138	1,14
100	220	20	180	8	18	111	119	135	128	128/135	158	1,30
125	250	22	210	8	18	136	145	158	152	158	188	1,78
150	285	22	240	8	23	161	173	188	178	178/188	212	2,26
175	315	22	270	8	23	184	199				242	2,65
200	340	24	295	8	23	212	225	238	235	235/238	268	3,22
250	395	26	350	12	23	264	279	294	288	288/294	320	4,10
300	445	26	400	12	23	315	329	344	338	338	370	4,76
350	505	26	460	16	23		362	376	376	376	430	5,50
400	565	32	515	16	27		413	430	430	430	482	8,50
450	615	32	565	20	27		465				530	9,00
500	670	34	620	20	27		517	533	533	517/533	585	11,20
550	730	34	675	20	30		565				635	12,00
600	780	36	725	20	30		618	633	633	618/645	685	12,50
650	835	40	780	24	30		663				740	18,00
700	895	40	840	24	30		721			740	800	21,00
750	950	40	890	24	30		765				860	38,00
800	1015	44	950	24	34		824			843	905	30,00
900	1115	48	1050	28	34		926			947	1005	34,00
1000	1230	52	1160	28	37		1028			1050	1105	48,00
1200	1455	60	1380	32	40		1232			1260		75,00
1400	1675	42	1590	36	42		1435					85,00

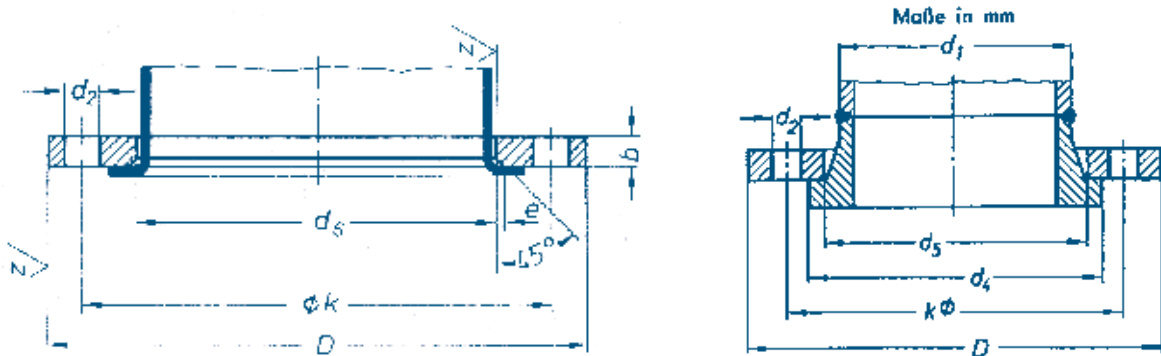

Typ A: Innendurchmesser passend zu metrischen Röhren mit ID = Nennweite „Papierabmessung“

Typ C: Innendurchmesser nach DIN 2642, passend zu Röhren nach ISO

Typ D: Innendurchmesser nach DIN 2673, passend zu Vorschweißbunden

Typ E: Innendurchmesser nach DIN 16963, passend zu Kunststoff-Bunden

Die Gewichte der Typen C, D und E sind unwesentlich geringer als die Ausführung A

Legierung: G-ALSi12 (Cu) Nr. 3.2583.01

Oberflächen: metallisch blank oder Epoxidharz farbbeschichtet RAL 7035

ALUMINIUM-Flansche

ähnlich DIN 2642

Bestellbeispiel: Al-Losflansch DIN 2642 / DN 100/104 (Typ A) blank/PN10 oder 114,3 (Typ C)

NW/ DN	LOSFLANSCH		BLINDFLANSCH	
	Anlehnung DIN 2642 / PN 10		ähnlich DIN 2527 / PN 10	
	blank	beschichtet	blank	beschichtet
10	●	○	X	○
15	●	●	X	○
20	●	●	●	○
25	●	●	○	○
32	●	●	○	○
40	●	●	●	○
50	●	●	○	○
65	●	●	●	○
80	●	●	●	○
100	●	●	●	○
125	●	●	●	○
150	●	●	●	○
175	○	○	○	○
200	●	●	●	○
250	●	●	○	○
300	●	●	○	○
350	●	○	●	○
400	●	○	●	○
450	○	○	●	○
500	●	●	○	○
600	●	○	○	○
700	○	○	○	○
800	○	○	○	○
900	X	○	○	○
1000	○	○	○	○



Sonderflansche auf Anfrage.

EDELSTAHL Vorschweißflansche

Rohranschluss metrisch / ISO DIN 2632/33/35 / EN1092-1/11

Rohranschlussmaße immer angeben!

Bestellbeispiel: Flansch EN1029-1/11 / DN 200/219,1 / PN16/ 6,3 / 1.4571

NW/ DN	1.4301 / 1.4307 / 1.4541 / 1.4541 / AISI 304				1.4571 / 1.4404 / AISI 316L			
		PN 10	PN 16	PN 25	PN 40	PN 10	PN 16	PN 25
10	X	X	X	○	X	○	X	○
15	X	X	X	○	X	●	X	●
20	X	●	X	●	X	●	X	●
25	X	●	X	●	X	●	X	●
32	X	●	X	●	X	●	X	●
40	X	●	X	●	X	●	X	●
50	X	●	X	●	X	●	X	●
65	X	●	X	●	X	●	X	●
80	X	●	X	●	X	●	X	●
100	X	●	X	●	X	●	X	●
125	X	●	X	○	X	●	X	●
150	X	●	X	○	X	●	X	○
200	●	●	○	○	●	●	○	○
250	○	●	○	○	●	●	○	○
300	○	○	○	○	●	●	○	○
350	○	○	○	○	●	●	○	○
400	○	○	○	○	●	●	○	○
500	○	○	○	○	○	○	○	○

EDELSTAHL Blindflansche

DIN 2527 / EN1092-1/5

Bestellbeispiel: Flansch EN1092-1/5 / DN 200 / PN 10 / 1.4571

NW/ DN	1.4301 / 1.4307 / 1.4541 / AISI 304				1.4571 / AISI 316L			
	PN 10	PN 16	PN 25	PN 40	PN 10	PN 16	PN 25	PN 40
10	X	○	X	○	X	○	X	○
15	X	○	X	○	X	●	X	●
20	X	○	X	○	X	○	X	●
25	X	○	X	○	X	●	X	●
32	X	●	X	●	X	●	X	●
40	X	○	X	●	X	●	X	●
50	X	●	X	○	X	●	X	○
65	X	○	X	○	X	●	X	○
80	X	○	X	○	X	●	X	○
100	X	●	X	○	X	●	X	○
125	X	○	X	○	X	●	X	○
150	X	○	X	○	X	●	X	○
200	○	○	○	○	●	●	○	○
250	○	○	○	○	●	●	○	○
300	○	○	○	○	●	●	○	○
350	○	○	○	○	○	○	○	○
400	○	○	○	○	○	○	○	○
500	○	○	○	○	○	○	○	○

Andere Druckstufen auf Anfrage.

EDELSTAHL glatte, lose Flansche

DIN 2576 / EN 1092-1/1 (GF) / DIN 2642 / EN 1092-1/2 (LF)

Rohranschlussmaße immer angeben!

Bestellbeispiel: Flansch EN 1092-1/1 / DN 200/219,1 / PN10 / 1.4301

NW/ DN	1.4301 / 1.4307 / 1.4541 / AISI 304			1.4571 / 1.4404 / AISI 316 L	
	GF / LF			GF / LF	
	PN 10	PN 16	PN 40	PN 16	PN 40
10	○	X	○	○	○
15	○	X	○	○	●
20	○	X	●	○	●
25	○	X	●	○	●
32	○	X	●	○	●
40	○	X	●	○	●
50	○	●	○	●	○
65	○	●	○	●	○
80	○	●	○	●	○
100	○	●	○	●	○
125	○	●	○	●	○
150	○	●	○	●	○
200	○	○	○	○	○
250	○	○	○	○	○
300	○	○	○	○	○
350	○	○	○	○	○
400	○	○	○	○	○
500	○	○	○	○	○

EDELSTAHL glatte Bunde

DIN 2642 / EN 1029-1/32

Rohranschlussmaße immer angeben!

Bestellbeispiel: Bund EN 1029-1/32 / DN 200/219,1 / PN10 / 1.4571

NW/ DN	1.4301 / 1.4307 / 1.4541 / AISI 304			1.4571 / AISI 316 L		
	DIN 2642	DIN 2655	DIN 2656	DIN 2642	DIN 2655	DIN 2656
	PN 10	PN 16	PN 40	PN 10	PN 16	PN 40
10	○	X	○	○	X	○
15	○	X	○	●	X	○
20	○	X	○	●	X	○
25	○	X	○	●	X	○
32	○	X	○	●	X	○
40	○	X	○	●	X	○
50	○	X	○	●	X	○
65	○	X	○	●	X	○
80	○	X	○	●	X	○
100	○	X	○	●	X	○
125	○	X	○	●	X	○
150	○	X	○	○	X	○
200	○	○	○	○	○	○
250	○	○	○	●	○	○
300	○	○	○	○	○	○
350	○	○	○	●	○	○
400	○	○	○	○	○	○
500	○	○	○	○	○	○

Andere Druckstufen auf Anfrage.

EDELSTAHL - Flansche

mit halber Blattstärke ähnlich EN 1092-1/2/5, gebohrt nach PN 10,
Rohranschluß metrisch / ISO

Rohranschlussmaße immer angeben!

Bestellbeispiel: Losflansch PN 10 DN 200/204 S=12 mm 1.4301

NW/ DN	Flanschstärke s mm	1.4301 / 1.4307 / 1.4541 / AISI 304			1.4571 / 1.4404 / AISI 316 L		
		Losflansche	Flachflansche	Blindflansche	Losflansche	Flachflansche	Blindflansche
10	10	●	○	○	○	○	○
15	10	●	●	○	○	●	●
20	10	●	●	●	●	●	●
25	10	●	●	○	●	●	●
32	10	●	●	○	●	●	●
40	10	●	●	○	●	●	●
50	10	●	●	●	●	●	●
65	10	●	●	●	●	●	●
80	10	●	●	●	●	●	●
100	10	●	●	●	●	●	●
125	12	●	●	●	●	●	●
150	12	●	●	●	●	●	●
200	12	●	●	●	●	●	●
250	15	●	●	●	●	●	●
300	15	●	●	●	●	●	●
350	15	●	●	○	●	●	●
400	15	●	●	●	○	○	●
500	20	●	●	●	○	●	○
600	20	●	●	●	○	○	○

Mauerflansche / Dichtflansche

aus 2 bzw. 3 mm Blech 1.4301 / 1.4307

passend für metrische Rohre zum Aufschweißen.

Bestellbeispiel: Mauerflansch DN 200/204 1.4301

NW/DN		NW/ DN	
50	○	250	○
65	○	300	○
80	○	350	○
100	○	400	○
125	○	500	○
150	○	600	○
200	○		

EDELSTAHL - Vorschweißbördel

METRISCH / ISO

PN 10, ähnlich DIN 2642 / EN1092-1/Typ 37

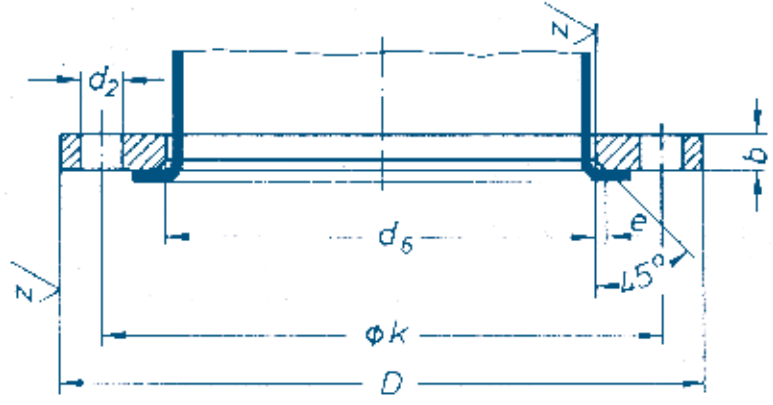

Bestellbeispiel: Bördel ähnlich DIN 2642 / DN 100 x 2,5 1.4301
oder 114,3 x 2,5 1.4571

NW/ DN	Bauhöhe ca.		1.4301 / AISI 304 / 1.4541 / AISI 321 / 1.4307 / 304L			1.4571 / 1.4404 / AISI 316L				
	metrisch mm	ISO mm	Einsatzblechstärke S2			Einsatzblechstärke S2				
			2,5 mm	3 mm	4 mm	2 mm	2,5 mm	3 mm	4 mm	5mm
10	7	7	●	○	X	●	○	○	X	X
15	4	9	●	○	○	X	●	○	○	X
20	10	11	●	○	○	X	●	○	○	X
25	11	12	●	○	X	X	●	●	X	X
32	13	14	●	●	○	X	●	●	○	X
40	16	16	●	●	○	X	●	●	○	X
50	17	21	●	●	○	X	●	●	●	X
65	20	23	●	●	○	X	●	●	○	X
80	22	23	●	●	○	X	●	●	●	X
100	26	29	●	●	○	X	●	●	●	X
125	28	30	●	●	○	X	●	●	○	X
150	29	30	●	●	●	X	●	●	●	X
200	25	30	●	●	●	X	●	●	●	○
250	25	30	●	●	○	X	●	●	●	○
300	35	35	○	●	○	X	○	●	●	●
350	35	35	X	●	●	X	X	●	●	●
400	40	40	X	●	●	X	X	●	●	○
450	45	45	X	●	●	X	X	●	●	○
500	45	45	X	●	●	X	X	●	●	○
600	45	45	X	○	●	X	X	○	●	○
700	45	45	X	○	○	X	X	○	○	○
800	45	45	X	○	○	X	X	○	○	○
900	45	45	X	X	○	X	X	X	○	○
1000	45	45	X	X	○	X	X	X	○	○

Sonderflansche und Zuschnitte aus EDELSTAHL

Gerne bieten wir unseren Kunden die Möglichkeit von Sonderflanschen und individuellen Zuschnitten.

Gängige Technologien zur Herstellung von Flanschen sind Schmieden, Walzen, Einrollen, Schneiden, Sägen, und Stanzen.

Die Fertigbearbeitung erfolgt durch Drehen, Bohren, Schleifen, Strahlen und Beizen.

Unsere Zuschnitte werden entweder gelasert, gesägt, plasmageschnitten oder wasserstrahlgeschnitten.

Unsere Werkstoffauswahl umfasst alle CrNi und CrNiMo – Stähle, hitzebeständige Edelmehle bis zu hochlegierten Qualitäten wie 1.4539, 1.4462, ...

Im Folgenden wollen wir in kurzer Form den wirtschaftlichen Einsatzbereich und die Eigenschaften der angeführten Schneidetechnologien darstellen:

Durch modernste Technologien
sind wir auch in der Lage komplizierte
Formen bzw. Geometrien,
sowie Schnitte in Rund- und Formrohren
anbieten zu können.

Technologie	Wirtschaftlicher Einsatzbereich	Eigenschaften
2D Laser	max. Länge/Breite: 4000/2000 mm max. Stärke: Edelstahl 20 mm Alu 10 mm Stahl 25 mm	Individuelle Formgebung, oxydfreie Schnittkanten ohne Gratbildung, geringe Aufhärtung bzw. thermische Veränderung an der Schnittfläche.
3D Rohrlaser	max. Rohrdurchmesser: 220 mm max. Rohrlänge: 6500 mm max. Wandstärke: Edelstahl 6 mm Alu 5 mm Stahl 8 mm	Möglichkeit von Trenn-, Gehrungs-, Form- und Durchdringungsschnitten in einem Arbeitsgang, gratfrei und ohne Materialdeformation, geringe Aufhärtung der Schnittfläche.
Wasserstrahlschneiden	max. Länge/Breite: 4000/2000 mm max. Stärke: 150 mm	Auch für dickere Materialien geeignet, völlig gratfrei und ohne Wärmebeeinflussung („Kaltschneideverfahren“), keine Aufhärtung, keine Materialspannungen. Umweltschonend und ohne giftige Dämpfe. Hohe Schnittpräzision.
Plasmaschneiden	max. Länge/Breite: 12000/3500 mm max. Stärke: 150 mm	Preisgünstig, ermöglicht hohe Schnittgeschwindigkeiten mit schmalen Wärmeeinflusszonen. Es entstehen Anlauffarben die leicht überschleifen werden müssen.
Sägen	max. Länge/Breite: 8000/3000 mm max. Stärke: 560 mm max. Durchmesser: 460 mm	Einfache Schnitte ohne spezielle Formgebung, geringere Schnittgeschwindigkeiten.

Sonderanfertigungen auf Anfrage jederzeit möglich.

Rohrschellen



EDELSTAHL - Rohrschellen

TYP D ähnlich DIN 3567 / DIN 3567 (V4A)

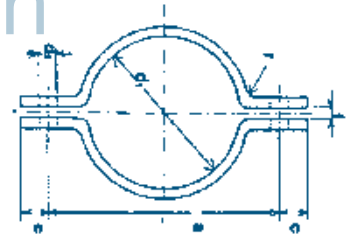

Bestellbeispiel: Rohrschelle Typ D für Rohraußendurchmesser 114,3 1.4301

NW/ DN	Rohraußen Ø (d1) mm	c	d2	f	r	Querschnitt für leichte Ausführung	V2A leichte Ausführung mit und ohne Schrauben und Muttern	V4A DIN-Ausführung ohne Schrauben und Muttern
15	18,0 - 21,3	10	9	5		30 x 3 / M 8 x 25	●	○
20	23,0 - 26,9						●	●
25	28,0 - 30,0						●	●
25	33,7	15	11,5	7		30 x 3 / M 10 x 30	●	●
32	35,0 - 38,0						●	●
32	42,4						●	●
40	43,0 - 45,0						●	●
40	48,3						●	●
50	53,0 - 57,0						●	●
50	60,3	18	14	9		40 x 4 / M 12 x 35	●	●
65	68,0 - 70,0						●	●
65	76,1						●	●
80	83,0 - 85,0						●	●
80	88,9						●	●
100	103,0 - 108,0						●	●
100	114,3	24	18	11		50 x 5 / M 16 x 45	●	●
125	128,0 - 133,0						●	●
125	139,7						●	●
150	153,0 - 155,0	30	23	14		50 x 6 / M 16 x 45	●	●
150	159						●	●
150	168,3						●	●
200	204,0 - 206,0						●	●
200	219,1						●	●
250	254,0 - 256,0						●	●
250	273	36	27	18		60 x 6 / M 24 x 65	●	●
300	304,0 - 308,0						●	●
300	323,9						●	●
350	354,0 - 358,0						●	●
400	404,0 - 410,0					70 x 8 / M 24 x 65	●	○

EDELSTAHL - Rohrschellen

TYP K Ausführung: gepresst
1.4301 / 1.4307 / AISI 304

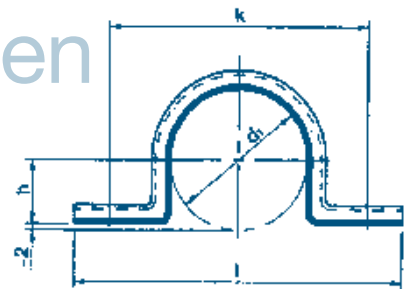

Bestellbeispiel: Rohrschelle Typ K für Rohraußendurchmesser 114,3 1.4301

NW/DN	Rohraußen Ø (d1) mm	k	l	h	s	ISO	METRISCH
15	21,3	59	79	9	1,5	●	○
20	26,9	66	86	11	1,5	●	○
25	33,7	77	97	15	1,5	●	○
32	42,4	77	97	19	1,5	●	○
40	48,3	93	113	22	1,5	●	○
50	60,3	105	125	28	1,5	●	○
65	76,1	115	139	36	2,0	●	X
80	88,9	137	161	42	2,0	●	X
100	114,3	163	187	55	2,5	○	○
125	139,7	190	215	72	2,5	○	X

Gewinde-Fittings & Armaturen



Gewinde-Fittings

V2A / AISI 304 (1.4301, 1.4541)

V4A / AISI 316 (1.4571, 1.4404)

Muffe DIN 2986

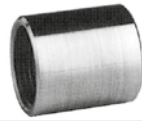

G	aus Rohr		aus Guss	
	ca. Länge mm	V4A	ca. Länge mm	V4A
1/8"	17	●	20	●
1/4"	25	●	25	●
3/8"	26	●	26	●
1/2"	34	●	34	●
3/4"	36	●	36	●
1"	43	●	43	●
1 1/4"	48	●	48	●
1 1/2"	48	●	48	●
2"	56	●	56	●
2 1/2"	65	●	65	●
3"	71	●	71	●
4"	83	○	83	●
5"		○		○
6"		○		○

Halbe Muffe DIN 2986



G	ca. Länge mm	V4A
1/8"	7 - 12	●
1/4"	11	●
3/8"	12	●
1/2"	15	●
3/4"	17	●
1"	20	●
1 1/4"	22	●
1 1/2"	22	●
2"	26	●
2 1/2"	30	●
3"	33	●
4"	39	●
5"		○
6"		○

Anschweißnippel DIN 2982

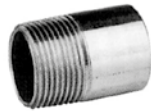

R	ca. Länge mm	V2A	V4A
1/8"	30	○	●
1/4"	30	○	●
3/8"	30	○	●
1/2"	35	○	●
3/4"	40	○	●
1"	40	○	●
1 1/4"	50	○	●
1 1/2"	50	○	●
2"	50	○	●
2 1/2"	60	○	●
3"	70	○	●
4"	80	○	●
5"		○	●
6"		○	●

Rohrnippel DIN 2982



G	ca. Länge mm	V4A
1/8"	16	●
1/4"	18	●
3/8"	22	●
1/2"	25	●
3/4"	30	●
1"	35	●
1 1/4"	38	●
1 1/2"	38	●
2"	45	●
2 1/2"	55	●
3"	60	●
4"		○
5"		○
6"		○

Schlauchnippel mit Anschweißende

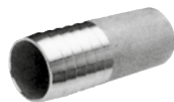

Ø	V4A
1/8"	○
1/4"	○
3/8"	●
1/2"	●
3/4"	●
1"	●
1 1/4"	○
1 1/2"	○
2"	○
2 1/2"	○
3"	○
4"	○

Schlauchnippel DIN 2982



R	V4A
1/8"	●
1/4"	●
3/8"	●
1/2"	●
3/4"	●
1"	●
1 1/4"	●
1 1/2"	●
2"	●
2 1/2"	○
3"	○
4"	●



**Rohrdoppelnippel
DIN 2982**



	ca. Länge	V4A
R	mm	
1/8"	30	●
1/4"	40	●
3/8"	40	●
1/2"	60	●
3/4"	60	●
1"	60	●
1 1/4"	80	●
1 1/2"	80	●
2"	100	●
2 1/2"	100	●
3"	120	●
4"	120	●
5"		○
6"		○

**Sechskantdoppelnippel
DIN 2982**



	V4A
R	
1/8"	●
1/4"	●
3/8"	●
1/2"	●
3/4"	●
1"	●
1 1/4"	●
1 1/2"	●
2"	●
2 1/2"	●
3"	●
4"	○

**Red. Sechskant-
doppelnippel**



**Reduziermuffe
DIN 2982**



**Reduzierstück
DIN 2982**



R x R	V4A
1/4" x 1/8"	●
3/8" x 1/8"	●
3/8" x 1/4"	●
1/2" x 1/4"	●
1/2" x 3/8"	●
3/4" x 3/8"	●
3/4" x 1/2"	●
1" x 1/2"	●
1" x 3/4"	●
1 1/4" x 1/2"	●
1 1/4" x 3/4"	●
1 1/4" x 1"	●
1 1/2" x 1,2"	●
1 1/2" x 1"	●
1 1/2" x 1 1/4"	●
2" x 1 1/4"	●
2" x 1 1/2"	●
2 1/2" x 2"	○
3" x 2 1/2"	●

G x G	V4A
1/4" x 1/8"	●
3/8" x 1/8"	●
3/8" x 1/4"	●
1/2" x 1/4"	●
1/2" x 3/8"	●
3/4" x 3/8"	●
3/4" x 1/2"	●
1" x 1/2"	●
1" x 3/4"	●
1 1/4" x 3/4"	●
1 1/4" x 1"	●
1 1/2" x 3/4"	●
1 1/2" x 1"	●
1 1/2" x 1 1/4"	●
2" x 1"	●
2" x 1 1/4"	●
2" x 1 1/2"	●
2 1/2" x 1 1/2"	●
2 1/2" x 2"	●
3" x 1 1/4"	●
3" x 2"	●
3" x 2 1/2"	●

R x G	V4A
1/4" x 1/8"	●
3/8" x 1/8"	●
3/8" x 1/4"	●
1/2" x 1/4"	●
1/2" x 3/8"	●
3/4" x 1/4"	●
3/4" x 3/8"	●
3/4" x 1/2"	●
1" x 3/8"	●
1" x 1/2"	●
1" x 3/4"	●
1 1/4" x 1/2"	●
1 1/4" x 3/4"	●
1 1/4" x 1"	●
1 1/2" x 3/4"	●
1 1/2" x 1"	●
1 1/2" x 1 1/4"	●
2" x 1"	●
2" x 1 1/4"	●
2" x 1 1/2"	●
2 1/2" x 2"	●
3" x 2 1/2"	●

Muffennippel lieferbar!

G ... zylindrisches Gewinde R ... kegeliges Gewinde

Sechskantstopfen DIN 2991



R	V4A
1/8"	●
1/4"	●
3/8"	●
1/2"	●
3/4"	●
1"	●
1 1/4"	●
1 1/2"	●
2"	●
2 1/2"	●
3"	●
4"	○

Vierkantstopfen DIN 2991



R	V4A
1/8"	●
1/4"	●
3/8"	●
1/2"	●
3/4"	●
1"	●
1 1/4"	●
1 1/2"	●
2"	●
2 1/2"	●
3"	●
4"	●

Sechskantkappe DIN 2986



R	V4A
1/8"	●
1/4"	●
3/8"	●
1/2"	●
3/4"	●
1"	●
1 1/4"	●
1 1/2"	●
2"	●
2 1/2"	●
3"	●
4"	○

Rundkappe DIN 2991



G	V4A
1/8"	●
1/4"	●
3/8"	●
1/2"	●
3/4"	●
1"	●
1 1/4"	●
1 1/2"	●
2"	●
2 1/2"	●
3"	○
4"	○

Rohrmutter DIN 431



G	V4A
1/8"	●
1/4"	●
3/8"	●
1/2"	●
3/4"	●
1"	●
1 1/4"	●
1 1/2"	●
2"	●
2 1/2"	●
3"	○
4"	○

Verschlußschrauben DIN 910



G	V4A
1/8"	●
1/4"	●
3/8"	●
1/2"	●
3/4"	●
1"	●
1 1/4"	●
1 1/2"	●
2"	●
2 1/2"	X
3"	X
4"	X

G ... zylindrisches Gewinde R ... kegeliges Gewinde

T-Stück DIN 2987



mit Innengewinde	V4A
G	
1/8"	●
1/4"	●
3/8"	●
1/2"	●
3/4"	●
1"	●
1 1/4"	●
1 1/2"	●
2"	●
2 1/2"	●
3"	●
4"	○

Winkel 45° DIN 2987



mit Innengewinde	V4A
G	
1/8"	●
1/4"	●
3/8"	●
1/2"	●
3/4"	●
1"	●
1 1/4"	●
1 1/2"	●
2"	●
2 1/2"	○
3"	○
4"	○

Kreuzstück DIN 2987



mit Innengewinde	V4A
G	
1/4"	●
3/8"	●
1/2"	●
3/4"	●
1"	●
1 1/4"	●
1 1/2"	●
2"	●
2 1/2"	○
3"	○
4"	○

Winkel 90° DIN 2987



mit Innen- und Außengewinde	V4A
G/R	
1/8"	●
1/4"	●
3/8"	●
1/2"	●
3/4"	●
1"	●
1 1/4"	●
1 1/2"	●
2"	●
2 1/2"	●
3"	●
4"	○

Bogen DIN 2983



mit Außengewinde	V4A
R	
1/8"	●
1/4"	●
3/8"	●
1/2"	●
3/4"	●
1"	●
1 1/4"	●
1 1/2"	●
2"	●
2 1/2"	●
3"	○
4"	○

Winkel 90° DIN 2987



mit Innengewinde	V4A
G	
1/8"	●
1/4"	●
3/8"	●
1/2"	●
3/4"	●
1"	●
1 1/4"	●
1 1/2"	●
2"	●
2 1/2"	○
3"	●
4"	○

G ... zylindrisches Gewinde R ... kegeliges Gewinde

Verschraubung beidseits Innengewinde I/I



konisch dichtend / flach dichtend	V4A
G	
1/8"	●
1/4"	●
3/8"	●
1/2"	●
3/4"	●
1"	●
1 1/4"	●
1 1/2"	●
2"	●
2 1/2"	●
3"	○
4"	○

Verschraubung einseitig Innengewinde anderseitig Außengewinde I/A



konisch dichtend / flach dichtend	V4A
G/R	
1/8"	●
1/4"	●
3/8"	●
1/2"	●
3/4"	●
1"	●
1 1/4"	●
1 1/2"	●
2"	●
2 1/2"	●
3"	○
4"	○

Anschweißverschraubung S/S

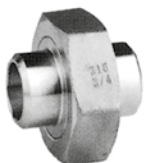

konisch dichtend / flach dichtend	V4A
Ø	
1/8"	●
1/4"	●
3/8"	●
1/2"	●
3/4"	●
1"	●
1 1/4"	●
1 1/2"	●
2"	●
2 1/2"	●
3"	○
4"	○

Verschraubung einseitig Außengewinde anderseitig Anschweißende A/S



konisch dichtend / flach dichtend	V4A
R	
1/8"	●
1/4"	●
3/8"	●
1/2"	●
3/4"	●
1"	●
1 1/4"	●
1 1/2"	●
2"	●
2 1/2"	○
3"	○
4"	X

Kugelhahn 2-teilig mit Innen- und Außengewinde



voller Durchgang mit Schließblase	V4A
G/R	
1/2"	●
3/4"	●
1"	●
1 1/4"	○
1 1/2"	●
2"	○

G ... zylindrisches Gewinde R ... kegeliges Gewinde

EDELSTAHL - Armaturen



**Kugelhahn
DIN 2987**

mit Innengewinde voller Durchgang	V4A
G	
1/4"	●
3/8"	●
1/2"	●
3/4"	●
1"	●
1 1/4"	●
1 1/2"	●
2"	●
2 1/2"	○
3"	○
4"	○

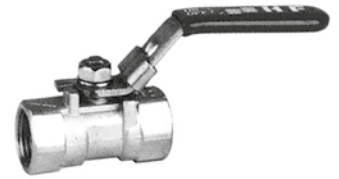

**Kugelhahn
DIN 2987**

mit Innengewinde reduzierter Durchgang	V4A
G	
1/4"	●
3/8"	●
1/2"	●
3/4"	●
1"	●
1 1/4"	●
1 1/2"	●
2"	●
2 1/2"	X
3"	X
4"	X



**Kugelhahn 3-teilig S/S
DIN 2999**

Ø	V4A
1/4"	○
3/8"	○
1/2"	●
3/4"	●
1"	●
1 1/4"	●
1 1/2"	●
2"	●
2 1/2"	○
3"	○
4"	○



**Kugelhahn 3-teilig
DIN 2999 mit Innengewinde**

G	V4A
1/4"	○
3/8"	○
1/2"	●
3/4"	●
1"	●
1 1/4"	●
1 1/2"	●
2"	●
2 1/2"	○
3"	○
4"	○



**3-Wege Kugelhahn
L-Bohrung DIN 2999**

G	V4A
1/4"	○
3/8"	○
1/2"	●
3/4"	●
1"	●
1 1/4"	●
1 1/2"	●
2"	●



**3-Wege Kugelhahn
T-Bohrung DIN 2999**

G	V4A
1/4"	○
3/8"	○
1/2"	●
3/4"	●
1"	●
1 1/4"	●
1 1/2"	●
2"	○

G ... zylindrisches Gewinde R ... kegeliges Gewinde

3 Wege Kugelhahn

Schaltmöglichkeiten

		T-Bohrung / T-configuration				L-Bohrung / L-configuration		
Handhebel- bzw. Antriebs- montage / Handle or actuator mounting	Art. VN, VC	1	2	3	4	5	6	7
	Art. PD	1	2	3	4	5	6	7
Stellung 0° / position 0°								
Stellung 90° / position 90°								

**Elektrische und pneumatische
Antriebe auf Anfrage!**

Rückschlagventil DIN 259/2999 Schrägsitzform PN 40 mit Innengewinde



G	V4A
1/4"	○
3/8"	●
1/2"	●
3/4"	●
1"	●
1 1/4"	●
1 1/2"	●
2"	●
2 1/2"	X
3"	X
4"	X

Schmutzfänger mit Innengewinde DIN 259/2999



G	V4A
1/4"	○
3/8"	●
1/2"	●
3/4"	●
1"	●
1 1/4"	●
1 1/2"	●
2"	●
2 1/2"	○
3"	○
4"	X

Stabstahl



Flachstahl

vom Band geschnitten EN 10058 (DIN 1017) 1.4301 / 1.4307

in HL zu 4m

Bestellbeispiel: Flachstahl EN 10058 (DIN 1017) 80 x 8 1.4301

Breite mm	DICKE mm													
	3		4		5		6		8		10		12	
		kg/m		kg/m		kg/m		kg/m		kg/m		kg/m		kg/m
10	●	0,24	○	0,32	○	0,40	X		X		X		X	
15	●	0,35	○	0,47	●	0,59	○	0,71	○		○		X	
20	●	0,47	●	0,63	●	0,79	●	0,94	●	1,26	●	1,57	○	
25	●	0,59	●	0,79	●	0,98	●	1,18	●	1,57	●	1,96	○	
30	●	0,71	●	0,94	●	1,18	●	1,41	●	1,88	●	2,36	○	2,83
35	○	0,82	○	1,10	○	1,37	●	1,65	○	2,20	○	2,75	○	
40	●	0,94	●	1,26	●	1,57	●	1,88	●	2,51	●	3,14	●	3,77
50	●	1,18	●	1,57	●	1,96	●	2,36	●	3,14	●	3,93	●	4,71
60	○	1,41	○	1,88	●	2,36	●	2,83	●	3,77	●	4,71	●	5,65
70	○	1,65	○	2,20	○	2,75	○	3,30	○	4,40	○	5,50	○	
80	○	1,88	○	2,51	●	3,14	●	3,77	●	5,02	●	6,28	●	7,54
90	X		X		○	3,53	○	4,24	○	5,65	○	7,07	○	
100	○	2,34	○	3,14	●	3,93	●	4,71	●	6,28	●	7,85	●	9,42
120	X		○		○	4,71	○	5,65	●	7,45	●	9,42	●	11,30

Flachstahl

vom Band geschnitten EN 10058 (DIN 1017) 1.4571 / 1.4404

in HL zu 4m

Bestellbeispiel: Flachstahl EN 10058 (DIN 1017) 80 x 8 1.4571

Breite mm	DICKE mm													
	3		4		5		6		8		10		12	
		kg/m		kg/m		kg/m		kg/m		kg/m		kg/m		kg/m
10	○	0,24	X		X		X		X		X		X	
15	○	0,35	○	0,47	○	0,59	○	0,71	X		X		X	
20	○	0,47	○	0,63	●	0,79	○	0,94	●	1,26	○	1,57	○	
25	○	0,59	●	0,79	●	0,98	●	1,18	●	1,57	●	1,96	○	
30	●	0,71	●	0,94	●	1,18	●	1,41	●	1,88	●	2,36	○	2,83
35	X	0,82	●	1,10	○	1,37	●	1,65	○	2,20	○	2,75	X	
40	●	0,94	●	1,26	●	1,57	●	1,88	●	2,51	●	3,14	○	3,77
50	○	1,18	○	1,57	●	1,96	●	2,36	●	3,14	●	3,93	○	4,71
60	○	1,41	○	1,88	●	2,36	●	2,83	●	3,77	●	4,71	○	5,65
70	X		X		●	2,75	○	3,30	○	4,40	○	5,50	X	
80	○	1,88	○	2,51	○	3,14	●	3,77	●	5,02	●	6,28	○	7,54
90	X		X		X		○	4,24	○	5,65	○	7,07	X	
100	X		X	3,14	○	3,93	●	4,71	●	6,28	●	7,85	○	9,42
110	X		●	3,45	X		X		X		X		X	
120	X		X		○	4,71	○	5,65	○	7,54	○	9,42	○	11,30

Flachstahl gewalzt

Vierkantstahl



EN 10278 (DIN 178) 1.4301, 1.4571

in HL zu ca. 3m

Bestellbeispiel: Vierkantstahl EN 10278 (DIN 178) 10 x 10 1.4571

mm	kg/m	1.4301	1.4571	mm	kg/m	1.4301	1.4571
6 x 6	0,28	○	●	15 x 15	1,77	○	○
8 x 8	0,50	○	●	20 x 20	3,14	○	○
10 x 10	0,79	○	●	25 x 25	4,91	○	○
12 x 12	1,13	○	●	30 x 30	7,07	○	○

Rundstahl



EN 10060 (DIN 1013)

in HL zu ca. 4 - 6m

Bestellbeispiel: Rundstahl EN 10060 (DIN 1013) 100 1.4571

Ø mm	kg/m	1.4301	1.4571 / 1.4404
50	15,41	○	○
60	22,20	○	○
70	30,21	○	○
80	39,46	○	●
90	49,94	○	●
100	61,65	○	●
110	74,60	○	○
120	88,80	○	●
130	104,20	○	○
140	120,80	○	●
150	138,70	○	●
160	157,80	○	○
170	178,20	○	○
180	199,80	○	○
190	222,60	○	○
200	246,80	○	○

T-Profil



ähnlich EN 10055 (DIN 1024)

in HL zu ca. 6m

Bestellbeispiel: T-Profil EN 10055 (DIN 1024) 40 x 40 x 4 1.4301

mm	kg/m	1.4301	1.4571
30 x 30 x 3	1,36	●	○
40 x 40 x 4	2,5	●	○
50 x 50 x 5	3,8	●	○
60 x 60 x 6	5,5	●	○
80 x 80 x 8	9,7	●	○

U-Profil



ähnlich EN 10279 (DIN 1026)

in HL zu ca. 6m

Bestellbeispiel: U-Profil EN 10279 (DIN 1026) 80 x 40 x 6 1.4301

mm	kg/m	1.4301	1.4571
40 x 20 x 4	2,3	●	○
50 x 25 x 5	4,1	●	○
60 x 30 x 6	5,1	●	○
80 x 40 x 6	7	●	○
100 x 50 x 6	8,94	●	○

Blankstahl

EN 10278 (DIN 671) h9



in HL zu ca. 3m

Bestellbeispiel: Blankstahl EN 10278 (DIN 671) h9 16 1.4301

Ø mm				GESCHLIFFEN	Theor. Gewicht
	1.4301 / 1.4307	1.4305	1.4404 / 1.4571	1.4301	kg/m
3	○	○	○	X	0,06
4	○	○	●	X	0,10
5	●	○	●	X	0,15
6	●	○	●	X	0,22
8	●	●	●	○	0,40
10	●	●	●	●	0,62
12	●	●	●	●	0,89
14	●	●	○	○	1,21
15	●	○	●	○	1,39
16	●	●	●	○	1,58
18	●	○	○	○	2,00
20	●	●	●	○	2,47
25	●	●	●	○	3,85
28	○	●	○	X	4,83
30	●	○	●	X	5,55
35	●	○	●	X	7,55
40	●	●	●	X	9,87
45	●	●	○	X	12,49
50	●	●	●	X	15,41
60	●	●	●	X	22,21
70	●	○	○	X	30,21
80	●	○	○	X	39,46

Winkelstahl

EN 10056-1 (DIN 1028)



in HL zu ca. 6m

Bestellbeispiel: Winkelstahl EN 10056-1 (DIN 1028) 50 / 50 x 5 1.4301

mm	1.4301 / 1.4307	1.4571	Theor. Gewicht
			kg/m
15/15 x 2	●	○	0,47
20/20 x 3	●	●	0,88
25/25 x 3	●	●	1,12
x 4	○	○	1,45
30/30 x 3	●	●	1,36
x 4	○	○	1,78
35/35 x 4	●	●	2,10
40/40 x 4	●	●	2,42
x 5	○	○	2,97
50/50 x 5	●	●	3,77
60/60 x 6	●	●	5,42
70/70 x 7	○	○	7,38
80/80 x 8	●	●	9,66
90/90 x 9	○	○	12,20
100/100 x 10	●	●	15,10



Ringraum Dichtungen Schweißdraht

Niro-Zubehör

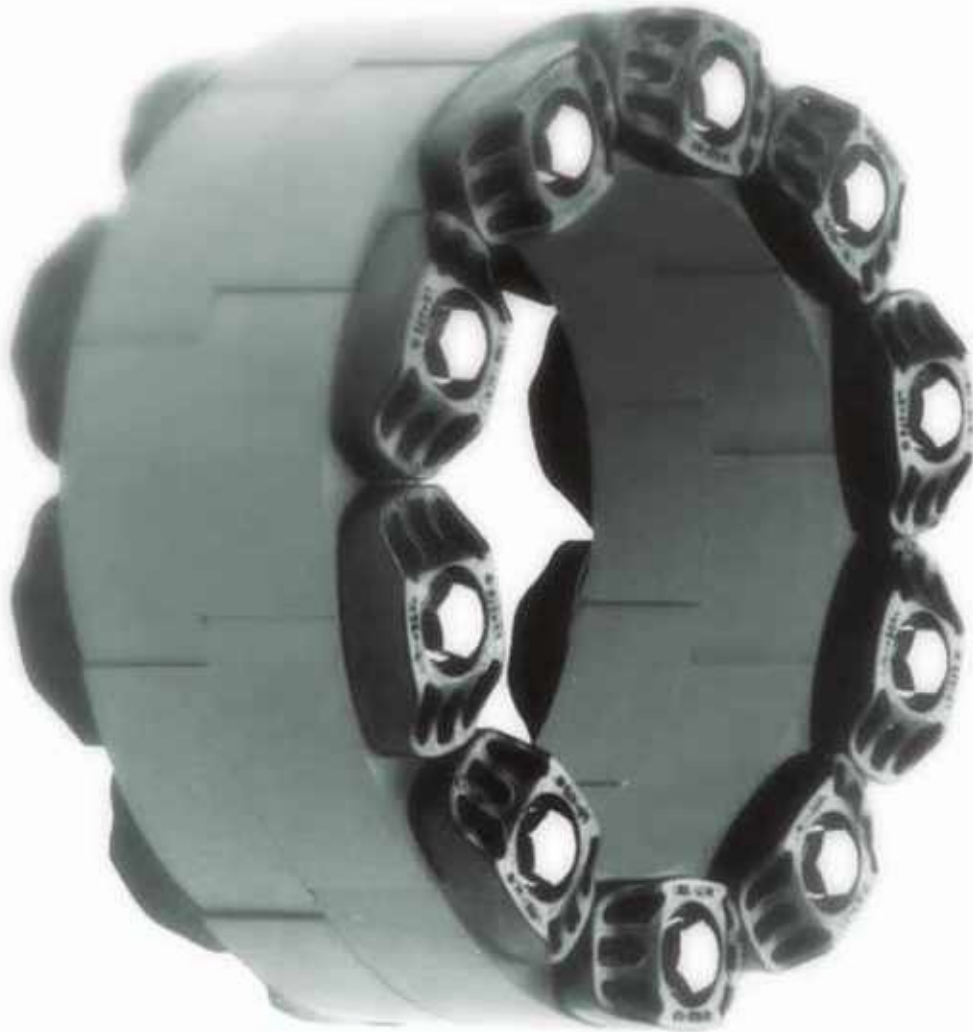

Rutschhemmende Leitersprossen

Wir führen rutschhemmende Leitersprossen für senkrechte, ortsfeste Leitern aus Stahl nach DIN 24532 ab Lager.

Die **ein- oder zweireihige Oberflächenprofilierung** gewährleistet eine gute Rutschhemmung und Verschmutzung ist weitgehend ausgeschlossen. Somit bieten die Sprossen auch bei extremen Arbeitsbedingungen gute Standsicherheit und entsprechen hohen Sicherheitsanforderungen.

Der Standard-Achsabstand der anzuschweisenden Leitern-Holme ist 500 mm und die Sprossen sind mit zum Holmdurchmesser passenden **ausgeklinkten Enden** ausgeführt. Bei einreihiger Profilierung beträgt der Holmrohrdurchmesser 33,7 mm und die Sprossentrittbreite 35 mm. Bei zweireihiger Profilierung beträgt der Holmrohrdurchmesser 48,3 mm und die Sprossentrittbreite 50 mm.

Die Sprossen sind aber auch mit geraden Enden in einer Länge von

2000 mm zum Selbstablängen lieferbar.

Als Werkstoffe sind **EDELSTAHL, Aluminium oder Stahl** verfügbar. **Gerr**

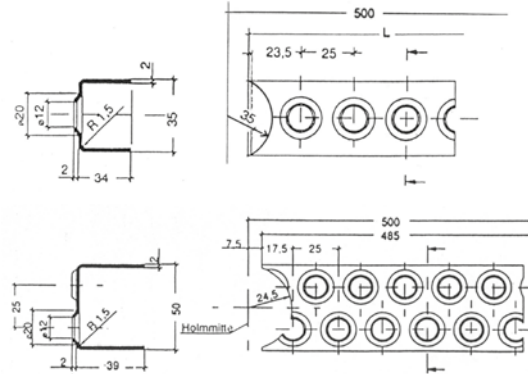

Ringraumdichtungen

- Robuste Gummiteile garantieren eine lange Lebensdauer
- Öl-, kraftstoff- lösungsmittelbeständig
- Auch für den nachträglichen Einbau bestens geeignet
- Leichte und schnelle Montage durch vormontierte Gliederbauweise
- Schrauben in Edelstahl V4A
- Absorbition von Stoß-, Geräusch- und Schwingungsbelastungen



Die radiale Ausdehnung der Gummiteile gewährleistet einen dauerhaften, druckdichten und sicheren Verschluss des Ringraumes.

Für Anfragen bzw. detailliertere Informationen wenden Sie sich bitte an unsere Kundenberater.

Auch für Auslegung und Berechnung stehen wir gerne zur Verfügung!

Schweisdraht

WIG/TIG Stäbe 1000 mm lang

W-Nr.	Durchmesser							
	1	1,2	1,6	2	2,4	3,2	4	5
1.4430	●	●	●	●	●	●	○	○

MIG - Drähte in Spulen 12 - 15 kg

W-Nr.	Durchmesser		
	0,8	1	1,2
1.4430	○	○	○

Andere Werkstoffe, z. B. 1.4539, auf Anfrage
Preise in EURO/kg, zuzüglich Legierungszuschlag

Niro - Zubehör

Artikelbezeichnung	ME	
3M Edelstahlreiniger	Spraydose 600 ml	Dose ●
Beizpaste	giftscheinfrei á 2 kg	kg ●
Schleif-Vlies	grob	Meter ●
	fein	Meter ●
	sehr fein	Meter ●
Niro-Drahtbürste 4-reihig		Stück ●
Nutbürste 3-reihig		Stück ●
Beizpinsel gekröpft 2"	L = 450 mm	Stück ●
Beizpinsel gerade 2"	L = 450 mm	Stück ●

Getränke- leitungsteile



EDELSTAHL - Getränkeleitungsrohre

nach EN 10357 (DIN 11850)

Längsnaht schutzgasgeschweißt, aus Kaltband III C, geschliffen bzw. gebürstet
Schweißnaht auf Wanddickenebene nachgearbeitet, kalibriert,
HL zu ca. 6m

Bestellbeispiel: Rohr EN 10357 52 x 1,5 PK1 1.4301 CC

NW/DN	AD x Wand mm	Gewicht kg/m	1.4301 / 1.4307 / AISI 304 Ausführung CC ungeglüht
15	18 x 1,0	0,42	○
20	22 x 1,0	0,51	○
25	28 x 1,0	0,66	○
	28 x 1,5	1,00	●
	29 x 1,5	1,03	●
32	34 x 1,0	0,82	○
	35 x 1,5	1,26	●
40	40 x 1,0	0,97	○
	40 x 1,5	1,45	●
	41 x 1,5	1,48	●
50	52 x 1,0	1,26	●
	52 x 1,5	1,90	●
	53 x 1,5	1,93	●
65	70 x 1,5	2,57	○
	70 x 2,0	3,43	●
80	85 x 2,0	4,16	●
100	104 x 2,0	5,03	●

Werkstoff 1.4404 auf Anfrage

EDELSTAHL - Getränkeleitungs- zubehör

nach DIN 11851

Bitte
Detailunterlagen
anfordern!



Schneidring- Verschraubungen



Schneidring-Verschraubungen Klemmring-Verschraubungen Hochdruck-Kugelhähne



Zur Verbindung von Rohren mit glatten Enden werden Schneidring- oder Klemmringverschraubungen nach DIN 2353 eingesetzt. Der Vorteil liegt in der **leichten Lösbarkeit** und in der **höheren Druckbeständigkeit**.

Für diese Verschraubungen wird vom Hersteller die Verwendung von nahtlosen, kaltgezogenen Edelstahlrohren – zunderfrei und wärmebehandelt nach DIN 17456/17458, Tol. nach DIN 2391, Bl. 1 in Werkstoff 1.4571 empfohlen....

Die Abstufung erfolgt in **3 Baureihen (LL, L, S)** und umfasst folgende Nenndruckbereiche bis 630 bar:

Baureihe	Rohrdurchmesser mm	Nenndruck bar
LL - sehr leicht	4 – 12	PN 100
L - leicht	6 – 18	PN 315
	22 – 42	PN 160
S - schwer	6 – 14	PN 630
	16 – 30	PN 400
	38	PN 250

Die Festigkeit der Verschraubungen ist so ausgelegt, dass sie bei den aufgeführten Nenndrücken eine ca. 4-fache Sicherheit gewährt. Bei vorwiegend ruhender Belastung und Temperaturen bis 120° C können die Betriebsdrücke gleich den Nenndrücken gewählt werden.

Bei höheren Beanspruchungen (Schwingungen, Druckstößen, usw.) wird die Anwendung der Baureihe „S“ empfohlen. Der Werkstoff 1.4571 **lässt folgenden Druckabschlag in Abhängigkeit der Temperatur zu:**

Temperatur ° C	Druckabschlag %
- 60 bis + 20	--
+ 50	4,5 %
+ 100	11 %
+ 200	20 %
+ 300	29 %
+ 400	33 %

Achtung: Bei Einsatz unterschiedlicher Verschraubungs- und Dichtungswerkstoffe gilt die jeweils niedrigste Temperaturangabe!

Preise &
Detailunterlagen
auf Anfrage!

Bandstähle & Bleche

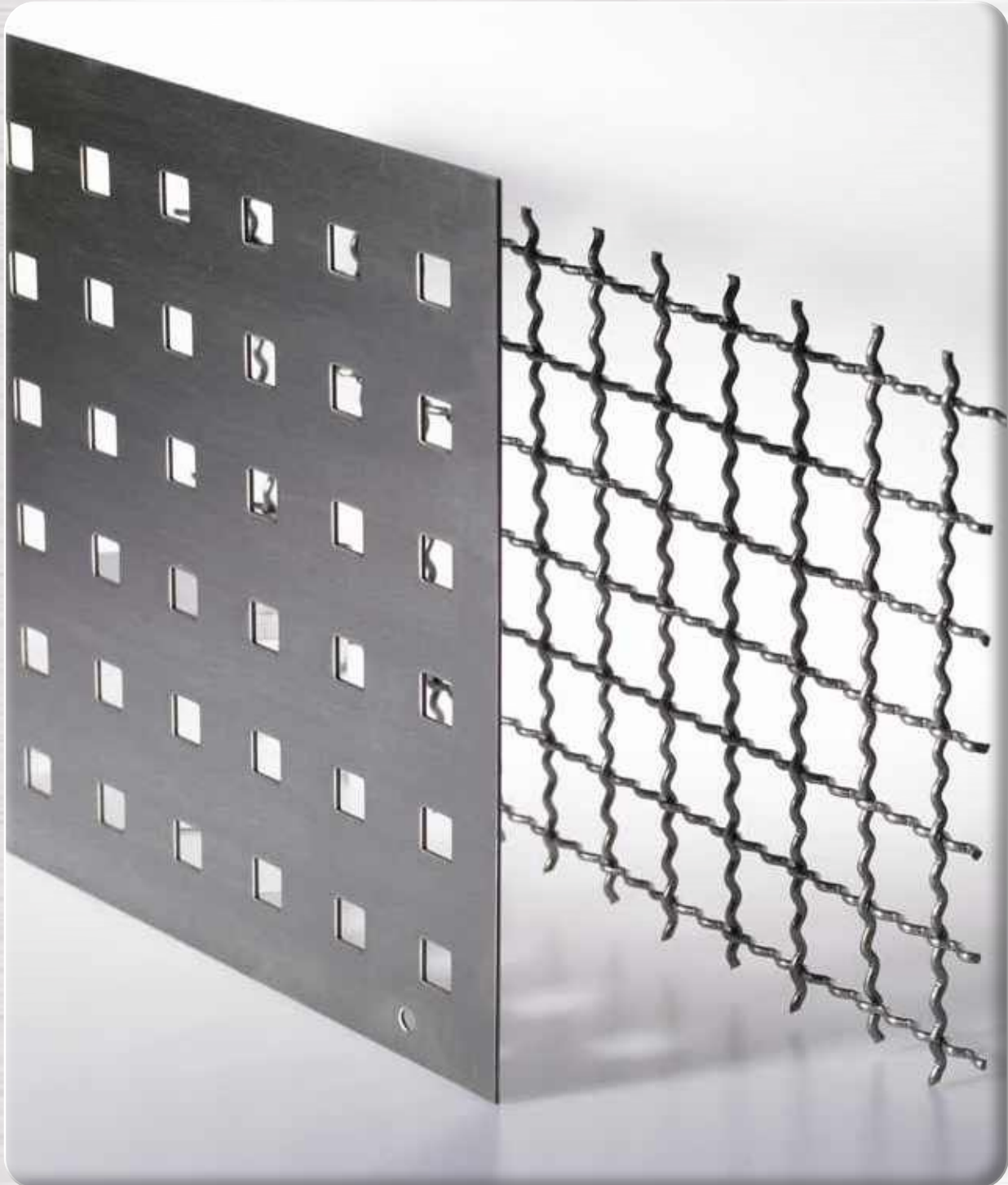

Rostfreie Bandstähle und Bleche

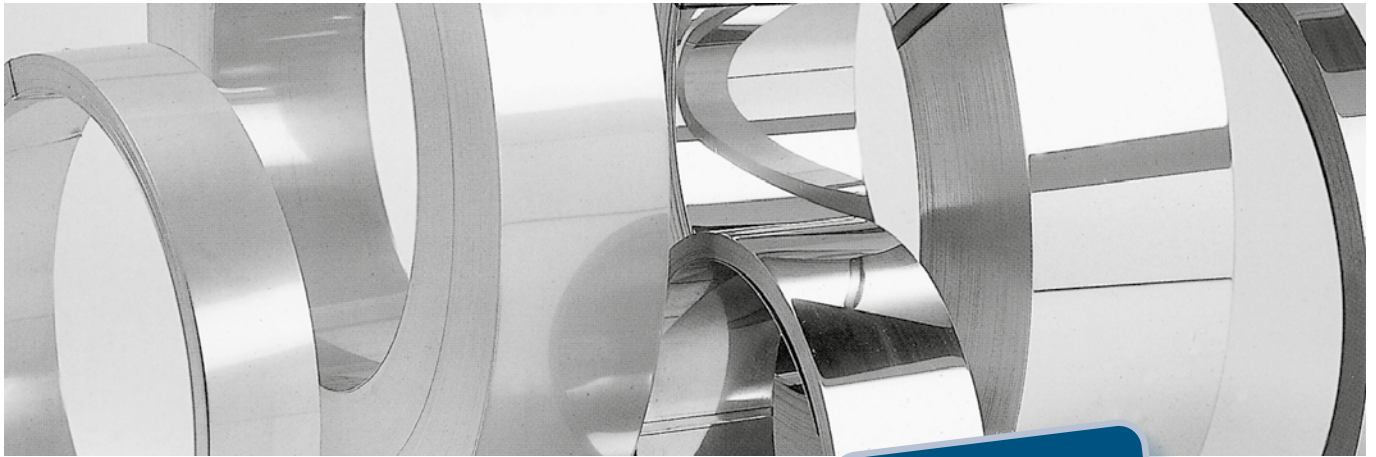

**Bänder
auf Anfrage!**

2000 x 1000 Normalformat (NF)
2500 x 1250 Mittelformat (MF)
3000 x 1500 Großformat (GF)
jeweils in Stärken von 0,5 - 20 mm
nach EN 10088-2 (DIN 17441) kaltgewalzt, Oberfläche 2B (IIIC) oder
nach EN 10088-2 (DIN 17440) warmgewalzt, Oberfläche 1D (IIA)

Gelochte Bleche

Standardrundlochung versetzt/gerade von \varnothing 1,0 - 20,0
Quadratlochung geradreihig von 5,0 - 20,0
Stärken von 0,8 - 1,5 mm
erhältlich in den Formaten NF, MF, GF
Sonstige Lochgeometrien auf Anfrage

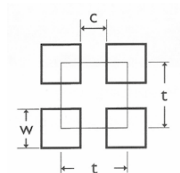
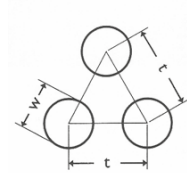
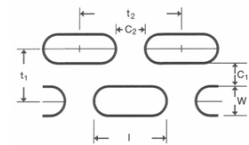

EDELSTAHL Tränenbleche

Nennstärke 3,0 - 15,0 + Träne
ebenfalls in den gängigen Formaten
NF, MF, GF erhältlich

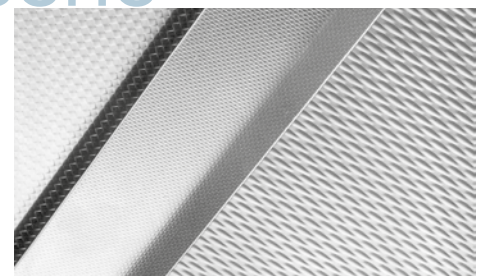

Struktur bzw. Dekorbleche

Stärke von 0,5 - 2,0 in den Formaten NF, MF, GF
und in verschiedenen Dekoren

**Bitte
Spezialunterlagen
anfordern!**



EDELSTAHL - Bleche

EN 10088-2

Sonderwerkstoffe, Formate und Zuschnitte auf Anfrage

NF...Normalformat

MF...Mittelformat

GF...Großformat

Dicke mm	Format	Abmessung mm	Gewicht pro Tfl.	kaltgewalzt DIN 17441		warmgewalzt DIN 17440		einseitig
				Oberfläche 2B (IIC)		Oberfläche 1D (IIA)		geschliffen
				1.4301	1.4571	1.4301	1.4571/1.4404	1.4301
0,5	NF	1000 x 2000	8 kg	○*	○**	X	X	X
	MF	1250 x 2500	13 kg	○	○	X	X	X
1,0	NF	1000 x 2000	16 kg	●	●	X	X	●
	MF	1250 x 2500	25 kg	○	○	X	X	●
	GF	1500 x 3000	36 kg	○	○	X	X	○
1,25	NF	1000 x 2000	20 kg	○	○	X	X	○
	MF	1250 x 2500	31 kg	○	○	X	X	○
	GF	1500 x 3000	45 kg	○	○	X	X	○
1,5	NF	1000 x 2000	24 kg	●	●	X	X	●
	MF	1250 x 2500	38 kg	●	○	X	X	●
	GF	1500 x 3000	54 kg	○	○	X	X	○
2,0	NF	1000 x 2000	32 kg	●	●	X	X	●
	MF	1250 x 2500	50 kg	●	○	X	X	●
	GF	1500 x 3000	72 kg	●	●	X	X	○
2,5	NF	1000 x 2000	40 kg	●	●	X	X	○
	MF	1250 x 2500	63 kg	○	○	X	X	○
	GF	1500 x 3000	90 kg	○	○	X	X	○
3,0	NF	1000 x 2000	48 kg	●	●	●	●	○
	MF	1250 x 2500	75 kg	●	○	○	○	○
	GF	1500 x 3000	108 kg	●	●	○	○	○
4,0	NF	1000 x 2000	64 kg	●	●	●	○	○
	MF	1250 x 2500	100 kg	○	○	○	○	○
	GF	1500 x 3000	144 kg	○	○	○	○	○
5,0	NF	1000 x 2000	80 kg	○	●	●	●	○
	MF	1250 x 2500	125 kg	○	○	○	○	○
	GF	1500 x 3000	180 kg	○	○	○	○	○
6,0	NF	1000 x 2000	96 kg	○	●	●	●	○
	MF	1250 x 2500	150 kg	○	○	○	○	○
	GF	1500 x 3000	216 kg	○	●	○	●	○
8,0	NF	1000 x 2000	128 kg	○	X	●	●	○
	MF	1250 x 2500	200 kg	○	X	○	○	○
	GF	1500 x 3000	288 kg	○	X	○	○	○
10	NF	1000 x 2000	160 kg	X	X	●	●	○
	MF	1250 x 2500	250 kg	X	X	○	○	○
	GF	1500 x 3000	360 kg	X	X	○	○	○
12	NF	1000 x 2000	192 kg	X	X	●	○	○
	MF	1250 x 2500	300 kg	X	X	○	○	○
	GF	1500 x 3000	432 kg	X	X	○	○	○
15	NF	1000 x 2000	240 kg	X	X	○	○	○
	MF	1250 x 2500	375 kg	X	X	○	○	○
	GF	1500 x 3000	540 kg	X	X	○	○	○
20	NF	1000 x 2000	320 kg	X	X	○	○	○
	MF	1250 x 2500	500 kg	X	X	○	○	○
	GF	1500 x 3000	720 kg	X	X	○	○	○
3,0	NF	1000 x 2000	56 kg	Tränenblech 1.4301		●		
5,0	NF	1000 x 2000	90kg	Tränenblech 1.4301		●		

* IIID - blankgeglüht 2R

** Stärke = 0,7 mm

Ergänzt wird unser EDELSTAHL Sortiment
für Industrie & Gewerbe durch folgende Produkte:

- EDELSTAHL Sonderanfertigungen
- EDELSTAHL für Bau & Architektur
- NIROSTICK Geländer-Stecksystem



Unsere Kundenberater informieren Sie gerne im Detail.



technometall EDELSTAHL GmbH
A-4600 Wels, Hans-Sachs-Straße 43
Tel +43 7242 44663, office@technometall.at
www.technometall.at